

- **SPRAY NOZZLE**    • **AUTO SPRAY GUN**
- **SPRAY SYSTEM & ENGINEERING**
- **PAINTING SYSTEM**



**SEJIN NOZZLE CO.,LTD**

[www.sejinnozzle.co.kr](http://www.sejinnozzle.co.kr)

■ **HEAD OFFICE & FACTORY**

360-70, Anhyeon-dong, Siheung-si, Gyeonggi, Korea



TEL : 82-31-404-9013 , 82-2-895-0160

FAX 82-31-404-9015

E-mail : [sejin@sejinnozzle.co.kr](mailto:sejin@sejinnozzle.co.kr)



With over 20 years of design and manufacturing experience, SEJIN NOZZLE is a leader in spray nozzle . Our sales specialists, engineers, and technical support staff are capable and willing to help solve the toughest of application problems in industries ranging from cleaning, rinsing, and washing to food and beverage from chemical processes to dust control, and many more. SEJIN NOZZLE is known not just for our exceptional quality but also for our industry-leading delivery and customer service.

Month Day	CONTENTS	
		
표 지 내 역	<ul style="list-style-type: none"> <li>• SPRAY NOZZLE    • AUTO SPRAY GUN</li> <li>• SPRAY SYSTEM &amp; ENGINEERING</li> <li>• PAINTING SYSTEM</li> </ul>	 <b>SEJIN NOZZLE CO.,LTD</b> www.sejinnozzle.co.kr ■ 360-70, Anhyeon-dong, Siheung-si, Gyeonggi, Korea TEL : 82-31-404-9013 , 82-2-895-0160 FAX : 82-31-404-9015 E-mail : sejin@sejinnozzle.co.kr





# C · O · N · T · E · N · T · S

## Spray patter and shape of Spray nozzle

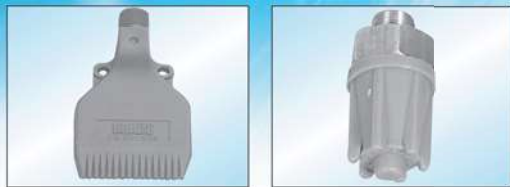

Common use spray nozzle

LOW NOISE AIR NOZZLE ..... 4

FOR AIR / STEAM ..... 5



VEEJET NOZZLE ..... 6

HIGH PRESSURE (MEG) ..... 10

AIR MIST NOZZLE ..... 11

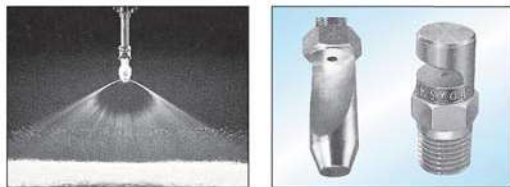

DESCALING NOZZLE ..... 12

SELF CLEANING NOZZLE ..... 13

HIGH PRESSURE (TC) ..... 14

FLO-JET NOZZLE ..... 15

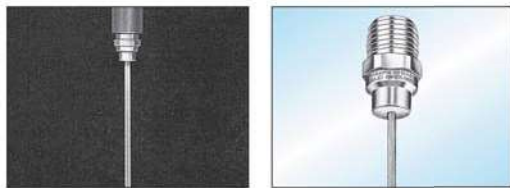

SOLID-JET NOZZLE ..... 17

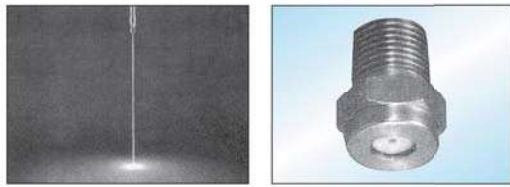

BRUSH HEADER ..... 19

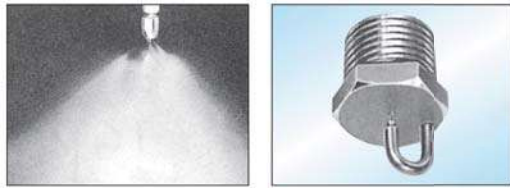

FINE ATOMIZING ..... 20



FULL CONE (FF, FW) ..... 21

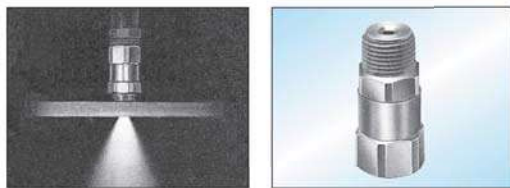

WALL MOUNTED FULL CONE ..... 26

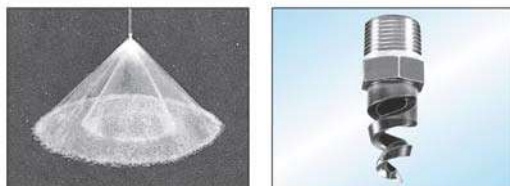

SPIRAL JET ..... 27



ANGLE TYPE FULL CONE

28



HOLLOW CONE NOZZLE

30



FOG JET NOZZLE  
CL7 TYPE

33



FLOMAX AIR ATOMIZING  
DRY NOZZLE

34

35

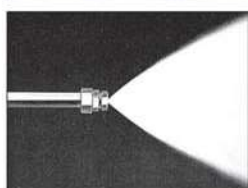

TANK CLEANING NOZZLE  
(Rotary/Fixed)

36



ACCESSORIES

39

BALL JOINT (BALL FITTING/ ADJUSTING ANGLE)  
CLIP-EYELET



AIR ATOMIZING NOZZLE  
(SIZE: 1/8, 1/4, 1/2)

40



MINI FOGGER  
AUTO SPRAY GUN

53

54



PRESSURE TANK  
AUTO SPRAY GUN

58



4

AIR NOZZLE

# AIR NOZZLE

## Low noise Air Nozzles

Features : Noiseless and Little air consumption

Material : ABS, Aluminum, SS-304

Temperature resistance : -30°C ~ +80°C

Maximum pressure : 7Bar

Typical Applications : Air dryer for parts, Burr removal, Air curtain, control of part moving...



	Air consumption V <sub>air</sub> (m <sup>3</sup> /h)				
	1bar	2bar	3bar	4bar	5bar
SJ-600	9	15	21	27	34
SJ-406	4	6	9	11	14



Air Curtain, Dryer (SJ-600)



Control for Part moving



Air Gun Set Set(SJ-406)



SJ-600ABS



SJ-600AL.SS



SJ-406

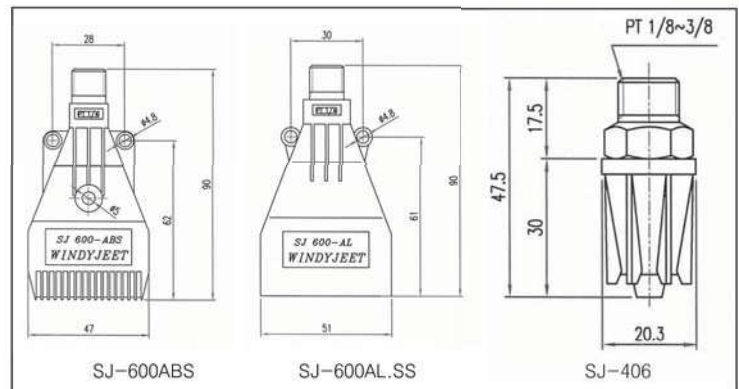
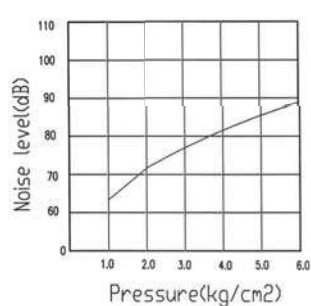
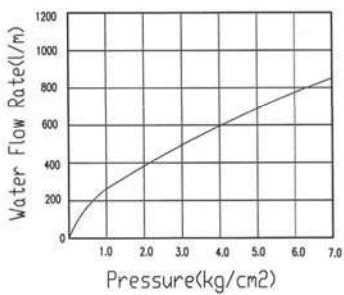

# AIR NOZZLE

## For Air / Steam

Features : Flat spray of Air or Steam

Construction : One piece nozzle or 3 piece assembled nozzle

Materials : Brass, 303, 304, 316 Stainless Steel.  
For steam application, Stainless Steel material is required

Applications : Drying, Air curtain, Humidification...

## Dimensions & Weights

Nozzle Number	Length Max (mm)	Weight Max (kg)
1/4T	25	0.06
1/4TT	44	0.05
3/8T	32	0.07
3/8TT	44	0.05



One piece (Type TR) female & male thread

Nozzle Number		Connection NPT or PT	Width of slot (mm)	Air Flow ℓ/min(Temp.15° C)				Steam Flow ( kg/h )				Coverage from nozzle 150mm	
One piece Type	Separate Type			1 kg/cm <sup>2</sup>	2 kg/cm <sup>2</sup>	4 kg/cm <sup>2</sup>	7 kg/cm <sup>2</sup>	1 kg/cm <sup>2</sup>	2 kg/cm <sup>2</sup>	4 kg/cm <sup>2</sup>	7 kg/cm <sup>2</sup>	1 kg/cm <sup>2</sup>	4 kg/cm <sup>2</sup>
1/4TL 3/8TL	1/4TTL 3/8TTL	1/4" 3/8"	0.20	21	38	65	102	0.75	1.4	2.3	3.7	275	419
1/4TP 3/8TP	1/4TTP 3/8TTP	1/4" 3/8"	0.33	41	60	99	153	1.5	2.1	3.6	5.5	152	254
1/4TQ 3/8TQ	1/4TTQ 3/8TTQ	1/4" 3/8"	0.58	77	111	190	305	2.8	4.0	6.8	11.5	228	330
1/4TR 3/8TR	1/4TTR 3/8TTR	1/4" 3/8"	1.1	132	198	345	540	4.7	7.1	12.3	19.5	158	241
1/4TU 3/8TU	1/4TTU 3/8TTU	1/4" 3/8"	1.3	210	335	570	880	7.6	12.0	20.3	32	275	368
1/4TV 3/8TV	1/4TTV 3/8TTV	1/4" 3/8"	2.3	430	700	1150	1725	15.3	25	42	63	238	343



Separate (Type TTR) female & male thread

주문방법 : 조합체의 경우

(예) 스테인레스로 숫나사의 경우 B 1/4TT-SS+R-SS

주문방법 : 단일체의 경우

B 1/4TR-SS

## FK Type

Features : Flat spray

Construction: One piece body without vane

Materials: Brass, 303 Stainless steel

Applications : Drying, Air curtain, Humidification...

## Dimensions

Nozzle Number	Length Max (mm)	Hex. (mm)
1/8FK	24	11
1/4FK	30~35	14
3/8FK	44	17



FK Type

Nozzle Number	Connection NPT or PT	Orifice Dia. (mm)	Air Flow ℓ/min(Temp.15° C)					Steam Flow ( kg/h )					Coverage from nozzle 150mm	
			0.7 kg/cm <sup>2</sup>	1.5 kg/cm <sup>2</sup>	2 kg/cm <sup>2</sup>	3 kg/cm <sup>2</sup>	3.5 kg/cm <sup>2</sup>	0.7 kg/cm <sup>2</sup>	1.5 kg/cm <sup>2</sup>	2 kg/cm <sup>2</sup>	3 kg/cm <sup>2</sup>	3.5 kg/cm <sup>2</sup>	0.7 kg/cm <sup>2</sup>	3.5 kg/cm <sup>2</sup>
1/8FK50	1/8"	0.6	4.5	6.4	7.6	10.5	11.6	0.16	0.23	0.27	0.37	0.41	51	127
1/8FK75	1/8"	0.7	6.2	9.1	10.8	14.7	16.7	0.23	0.33	0.39	0.53	0.60	64	140
1/8FK1	1/8"	0.8	9.6	13.7	16.4	22	25	0.34	0.49	0.59	0.80	0.90	76	152
1/8FK1.5	1/8"	1.0	15.3	22	26	36	40	0.54	0.78	0.94	1.3	1.5	89	165
1/8FK2	1/8"	1.2	19.3	28	33	45	51	0.68	1.0	1.2	1.6	1.8	102	190
1/8FK3	1/8"	1.4	31	47	56	77	85	1.1	1.7	2.0	2.7	3.0	127	203
1/8FK5	1/8"	1.9	54	76	91	124	139	1.9	2.7	3.3	4.5	5.0	152	267
1/8FK7.5	1/8"	2.3	79	117	140	189	210	2.9	4.2	5.0	6.8	7.6	152	267
1/8FK10	1/8"	2.6	110	159	190	255	290	3.9	5.7	6.8	9.2	10.4	178	279
1/8FK15	1/8"	3.3	181	260	310	420	475	6.5	9.3	11.2	15.0	17.1	178	305
1/8FK18	1/8"	3.6	205	300	355	485	540	7.4	10.7	12.7	17.4	19.5	203	330
1/4FK20	1/4"	3.8	225	325	385	520	590	8.0	11.6	13.8	18.8	21	216	368
3/8K30	3/8"	4.6	320	465	560	760	850	11.6	16.8	20	27	30	216	394
3/8K40	3/8"	5.3	440	640	760	1050	1160	15.7	23	27	37	42	216	406

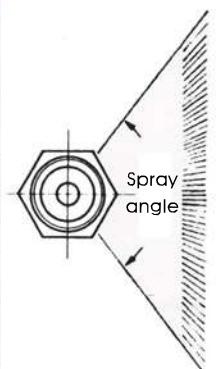

# FLAT NOZZLE

## V TYPE

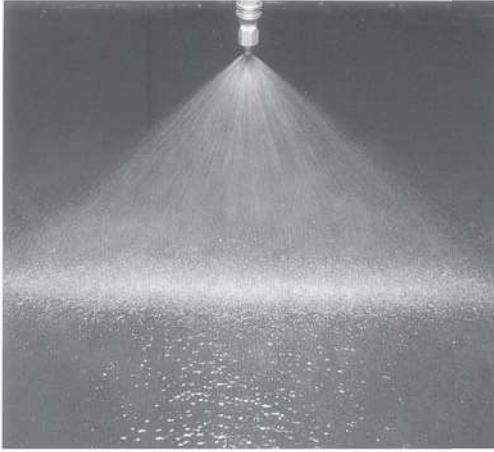

### Features

- Flat spray pattern distributes the liquid as a flat- or sheet-type spray.
- Small- to medium-sized drops.
- Uniform distribution over a wide range of flow rates and pressures.
- Specially tapered spray pattern is ideal for use in manifold and header applications.

### Materials

- 303, 304, 316 Stainless Steel, Brass, and other materials available upon request.

### Pipe Size

- PT, NPT 1/8" ~2"

### Applications

- Fire suppression/prevention, Air washing
- Cooling and quenching, Dust control
- Gas washing, Scrubbers

## Dimensions & Weights

Type V			
Nozzle Number	Hex. Max (mm)	Length Max (mm)	Weight Max (kg)
1/8V	11	22	0.014
1/4V	14	25	0.02
3/8V	17	32	0.04
1/2V	22	38	0.06
3/4V	27	51	0.14

Type V			
Nozzle Number	Hex. Max (mm)	Length Max (mm)	Weight Max (kg)
1v	33	64	0.28
1 1/4V	43	95	0.57
2V	60	127	1.93



SPRAY PATTE



FLAT TYPE (One piece)

## DOVETEL TYPE



## NOZZLE TIP ASSEMBLE EXAMPLES

1/4T-SS Female

1/4TT-SS Male

Deflector type

Flat type

Round type

1/4TT-SS Male  
1/4TT-BRASS Male

1/4T-SS Female  
1/4T-BRASS Female

Filter 200mesh  
100mesh  
50mesh

CAP

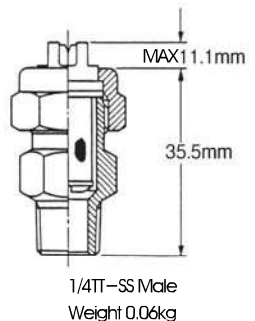
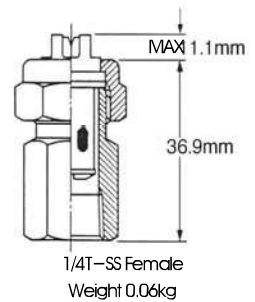









# VEEJET NOZZLE HIGH PRESSURE WASHING FLAT SPRAY NOZZLE

## MEG, WEG, EG TYPE

### Features

- High pressure, high impact solid stream (0° ) or flat fan spray pattern.
- Medium-sized drops.
- Spray angles of 5° to 65° at operating pressures from 20 to 210 kg/cm<sup>2</sup>.
- Quick visual reference for spray alignment with milled side flats.
- Longer wear life and flow control accuracy with especially hardened stainless steel construction.

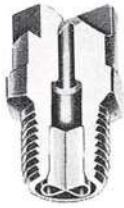

Cross section of MEG Type  
-Uniform distribution by using internal guide vane to stabilize liquid turbulence.



Type 1/8 MEG  
Type 1/4 MEG



Type 1/8 WEG  
Type 1/4 WEG



EG Tip Type  
EG spray tips produce a uniform spray distribution of medium sized droplets. The spray tip orifice is precision machined to accurately control flow rates.



Uniform flat spray pattern

Angle	Nozzle Number					Orifice Dia. (mm)	Capacity ℓ/min									
	Pipe Size						20 kg/cm <sup>2</sup>	30 kg/cm <sup>2</sup>	40 kg/cm <sup>2</sup>	50 kg/cm <sup>2</sup>	60 kg/cm <sup>2</sup>	70 kg/cm <sup>2</sup>	80 kg/cm <sup>2</sup>	100 kg/cm <sup>2</sup>	120 kg/cm <sup>2</sup>	140 kg/cm <sup>2</sup>
	1/8" PT or NPT Male	1/8" PT or NPT Female	1/4" PT or NPT Male	1/4" PT or NPT Female	TIP											
65°	1/8 MEG6504	1/8 WEG6504	1/4 MEG6504	1/4 WEG6504	6504EG	1.19	4.0	4.9	5.9	6.3	6.9	7.5	8.0	9.0	9.8	10.6
	1/8 MEG65045	1/8 WEG65045	1/4 MEG65045	1/4 WEG65045	65045EG	1.27	4.6	5.6	6.5	7.2	7.9	8.6	9.2	10.2	11.2	12.1
	1/8 MEG6505	1/8 WEG6505	1/4 MEG6505	1/4 WEG6505	6505EG	1.35	5.0	6.1	7.1	7.9	8.7	9.4	10.0	11.2	12.3	13.2
	1/8 MEG65055	1/8 WEG65055	1/4 MEG65055	1/4 WEG65055	65055EG	1.40	5.6	6.8	7.9	8.8	9.7	10.4	11.2	12.5	13.7	14.8
	1/8 MEG6506	1/8 WEG6506	1/4 MEG6506	1/4 WEG6506	6506EG	1.42	6.0	7.4	8.5	9.5	10.4	11.2	12.0	13.4	14.7	15.9
	1/8 MEG6507	1/8 WEG6507	1/4 MEG6507	1/4 WEG6507	6507EG	1.60	7.0	8.6	9.9	11.1	12.1	13.1	14.0	15.7	17.2	18.5
	1/8 MEG6508	1/8 WEG6508	1/4 MEG6508	1/4 WEG6508	6508EG	1.70	8.2	10.0	11.5	12.9	14.1	15.3	16.3	18.2	20.0	21.6
	1/8 MEG6509	1/8 WEG6509	1/4 MEG6509	1/4 WEG6509	6509EG	1.80	9.2	11.2	12.9	14.5	15.9	17.1	18.3	20.5	22.4	24.2
	1/8 MEG6510	1/8 WEG6510	1/4 MEG6510	1/4 WEG6510	6510EG	1.91	10.2	12.4	14.4	16.1	17.6	19.0	20.3	22.7	24.9	25.9
	1/8 MEG6515	1/8 WEG6515	1/4 MEG6515	1/4 WEG6515	6515EG	2.34	15.2	18.6	21.4	24.0	26.3	28.4	30.3	33.9	37.1	40.1
	1/8 MEG6520	1/8 WEG6520	1/4 MEG6520	1/4 WEG6520	6520EG	2.69	20.2	24.7	28.5	31.9	34.9	37.7	40.3	45.1	49.4	53.4
	50°	1/8 MEG5003	1/8 WEG5003	1/4 MEG5003	1/4 WEG5003	5003EG	1.09	3.0	3.68	4.25	4.75	5.20	5.62	6.01	6.72	7.36
1/8 MEG5004		1/8 WEG5004	1/4 MEG5004	1/4 WEG5004	5004EG	1.19	4.0	4.9	5.7	6.3	6.9	7.5	8.0	9.0	9.8	10.6
1/8 MEG5005		1/8 WEG5005	1/4 MEG5005	1/4 WEG5005	5005EG	1.35	5.0	6.1	7.1	7.9	8.7	9.4	10.0	11.2	12.3	13.2
1/8 MEG50055		1/8 WEG50055	1/4 MEG50055	1/4 WEG50055	50055EG	1.40	5.6	6.8	7.9	8.8	9.7	10.4	11.2	12.5	13.7	14.8
1/8 MEG5006		1/8 WEG5006	1/4 MEG5006	1/4 WEG5006	5006EG	1.42	6.0	7.4	8.5	9.5	10.4	11.2	12.0	13.4	14.7	15.9
1/8 MEG5007		1/8 WEG5007	1/4 MEG5007	1/4 WEG5007	5007EG	1.60	7.0	8.6	9.9	11.1	12.1	13.1	14.0	15.7	17.2	18.5
1/8 MEG5008		1/8 WEG5008	1/4 MEG5008	1/4 WEG5008	5008EG	1.70	8.2	10.0	11.5	12.9	14.1	15.3	16.3	18.2	20.0	21.6
1/8 MEG5009		1/8 WEG5009	1/4 MEG5009	1/4 WEG5009	5009EG	1.80	9.2	11.2	12.9	14.5	15.9	17.1	18.3	20.5	22.4	24.2
1/8 MEG5010		1/8 WEG5010	1/4 MEG5010	1/4 WEG5010	5010EG	1.91	10.2	12.4	14.4	16.1	17.6	19.0	20.3	22.7	24.9	25.9
1/8 MEG5015		1/8 WEG5015	1/4 MEG5015	1/4 WEG5015	5015EG	2.34	15.2	18.6	21.4	24.0	26.3	28.4	30.3	33.9	37.1	40.1
1/8 MEG5020		1/8 WEG5020	1/4 MEG5020	1/4 WEG5020	5020EG	2.69	20.2	24.7	28.5	31.9	34.9	37.7	40.3	45.1	49.4	53.4
40°		1/8 MEG4003	1/8 WEG4003	1/4 MEG4003	1/4 WEG4003	4003EG	1.09	3.00	3.68	4.25	4.75	5.20	5.62	6.01	6.72	7.36
	1/8 MEG4004	1/8 WEG4004	1/4 MEG4004	1/4 WEG4004	4004EG	1.19	4.0	4.9	5.7	6.3	6.9	7.5	8.0	9.0	9.8	10.6
	1/8 MEG40045	1/8 WEG40045	1/4 MEG40045	1/4 WEG40045	40045EG	1.27	4.6	5.6	6.5	7.2	7.9	8.6	9.2	10.2	11.2	12.1
	1/8 MEG4005	1/8 WEG4005	1/4 MEG4005	1/4 WEG4005	4005EG	1.35	5.0	6.1	7.1	7.9	8.7	9.4	10.0	11.2	12.3	13.2
	1/8 MEG40055	1/8 WEG40055	1/4 MEG40055	1/4 WEG40055	40055EG	1.40	5.6	6.8	7.9	8.8	9.7	10.4	11.2	12.5	13.7	14.8
	1/8 MEG4006	1/8 WEG4006	1/4 MEG4006	1/4 WEG4006	4006EG	1.42	6.0	7.4	8.5	9.5	10.4	11.2	12.0	13.4	14.7	15.9
	1/8 MEG40065	1/8 WEG40065	1/4 MEG40065	1/4 WEG40065	40065EG	1.52	6.6	8.1	9.3	10.4	11.4	12.3	13.2	14.7	16.1	17.4
	1/8 MEG4007	1/8 WEG4007	1/4 MEG4007	1/4 WEG4007	4007EG	1.60	7.0	8.6	9.9	11.1	12.1	13.1	14.0	15.7	17.2	18.5
	1/8 MEG40075	1/8 WEG40075	1/4 MEG40075	1/4 WEG40075	40075EG	1.65	7.6	9.3	10.7	12.0	13.1	14.2	15.2	17.0	18.6	20.1
	1/8 MEG4008	1/8 WEG4008	1/4 MEG4008	1/4 WEG4008	4008EG	1.70	8.2	10.0	11.5	12.9	14.1	15.3	16.3	18.2	20.0	21.6
	1/8 MEG40085	1/8 WEG40085	1/4 MEG40085	1/4 WEG40085	40085EG	1.75	8.6	10.5	12.1	13.6	14.9	16.1	17.2	19.2	21.0	22.7
	1/8 MEG4009	1/8 WEG4009	1/4 MEG4009	1/4 WEG4009	4009EG	1.80	9.2	11.2	12.9	14.5	15.9	17.1	18.3	20.5	22.4	24.2
25°	1/8 MEG2502	1/8 WEG2502	1/4 MEG2502	1/4 WEG2502	2502EG	0.91	2.00	2.45	2.83	3.17	3.47	3.75	4.01	4.48	4.91	5.30
	1/8 MEG2503	1/8 WEG2503	1/4 MEG2503	1/4 WEG2503	2503EG	1.09	3.00	3.68	4.25	4.75	5.20	5.62	6.01	6.72	7.36	7.96
	1/8 MEG2504	1/8 WEG2504	1/4 MEG2504	1/4 WEG2504	2504EG	1.19	4.0	4.9	5.7	6.3	6.9	7.5	8.0	9.0	9.8	10.6
	1/8 MEG25045	1/8 WEG25045	1/4 MEG25045	1/4 WEG25045	25045EG	1.27	4.6	5.6	6.5	7.2	7.9	8.6	9.2	10.2	11.2	12.1
	1/8 MEG2505	1/8 WEG2505	1/4 MEG2505	1/4 WEG2505	2505EG	1.35	5.0	6.1	7.1	7.9	8.7	9.4	10.0	11.2	12.3	13.2
	1/8 MEG25055	1/8 WEG25055	1/4 MEG25055	1/4 WEG25055	25055EG	1.40	5.6	6.8	7.9	8.8	9.7	10.4	11.2	12.5	13.7	14.8
	1/8 MEG2506	1/8 WEG2506	1/4 MEG2506	1/4 WEG2506	2506EG	1.42	6.0	7.4	8.5	9.5	10.4	11.2	12.0	13.4	14.7	15.9
	1/8 MEG25065	1/8 WEG25065	1/4 MEG25065	1/4 WEG25065	25065EG	1.52	6.6	8.1	9.3	10.4	11.4	12.3	13.2	14.7	16.1	17.4
	1/8 MEG2507	1/8 WEG2507	1/4 MEG2507	1/4 WEG2507	2507EG	1.60	7.0	8.6	9.9	11.1	12.1	13.1	14.0	15.7	17.2	18.5
	1/8 MEG25075	1/8 WEG25075	1/4 MEG25075	1/4 WEG25075	25075EG	1.65	7.6	9.3	10.7	12.0	13.1	14.2	15.2	17.0	18.6	20.1
	1/8 MEG2508	1/8 WEG2508	1/4 MEG2508	1/4 WEG2508	2508EG	1.70	8.2	10.0	11.5	12.9	14.1	15.3	16.3	18.2	20.0	21.6
	1/8 MEG25085	1/8 WEG25085	1/4 MEG25085	1/4 WEG25085	25085EG	1.75	8.6	10.5	12.1	13.6	14.9	16.1	17.2	19.2	21.0	22.7
1/8 MEG2509	1/8 WEG2509	1/4 MEG2509	1/4 WEG2509	2509EG	1.80	9.2	11.2	12.9	14.5	15.9	17.1	18.3	20.5	22.4	24.2	
1/8 MEG25095	1/8 WEG25095	1/4 MEG25095	1/4 WEG25095	25095EG	1.85	9.6	11.7	13.6	15.2	16.6	17.9	19.2	21.4	23.5	25.4	
1/8 MEG2510	1/8 WEG2510	1/4 MEG2510	1/4 WEG2510	2510EG	1.91	10.2	12.4	14.4	16.1	17.6	19.0	20.3	22.7	24.9	25.9	
1/8 MEG25105	1/8 WEG25105	1/4 MEG25105	1/4 WEG25105	25105EG	1.96	10.6	13.0	15.0	16.7	18.3	19.8	21.2	23.7	25.9	28.0	
1/8 MEG2511	1/8 WEG2511	1/4 MEG2511	1/4 WEG2511	2511EG	1.98	11.2	13.7	15.8	17.6	19.3	20.9	22.3	25.0	27.3	29.5	
1/8 MEG25115	1/8 WEG25115	1/4 MEG25115	1/4 WEG25115	25115EG	2.03	11.6	14.2	16.4	18.3	20.1	21.7	23.2	25.9	28.4	30.7	
1/8 MEG2512	1/8 WEG2512	1/4 MEG2512	1/4 WEG2512	2512EG	2.08	12.2	14.9	17.2	19.2	21.1	22.8	24.3	27.2	29.8	32.2	
1/8 MEG2513	1/8 WEG2513	1/4 MEG2513	1/4 WEG2513	2513EG	2.13	12.6	15.4	17.8	19.9	21.8	23.6	25.2	28.2	30.8	33.3	
1/8 MEG2514	1/8 WEG2514	1/4 MEG2514	1/4 WEG2514	2514EG	2.16	13.2	16.1	18.6	20.8	22.8	24.6	26.3	29.4	32.2	34.2	
1/8 MEG2515	1/8 WEG2515	1/4 MEG2515	1/4 WEG2515	2515EG	2.26	14.2	17.3	20.0	22.4	24.5	26.5	28.3	31.7	34.7	37.5	

# AIR MIST NOZZLES (CASTER NOZZLE)



## Features

- Uniform water flow distribution
- Small mean particle diameter, and small discrepancy.
- Superwide angle spray type is manufacturable.

## Applications

- Sprinkling of chemicals,
- Humidifying in paper mill
- Cooling of various high temperature gases

## Materials

- 303, 304, 316 Stainless Steel, and Tungsten,
- Special material on request

### Compact type

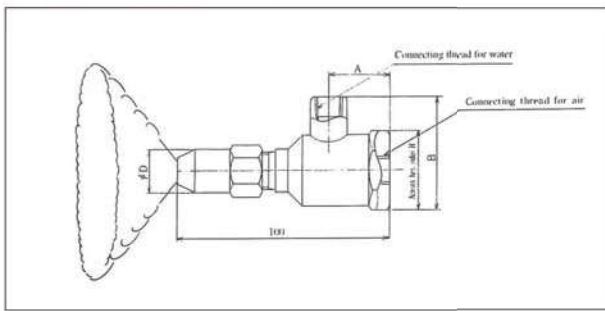

### Straight type

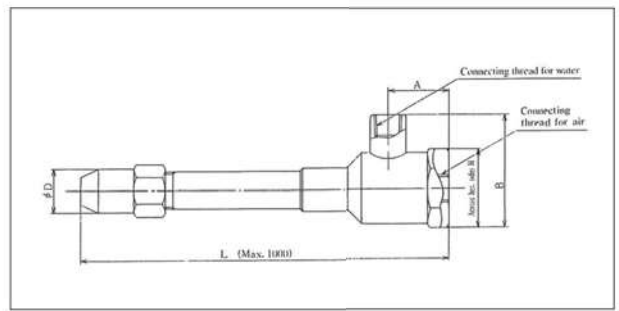

### Elbow type

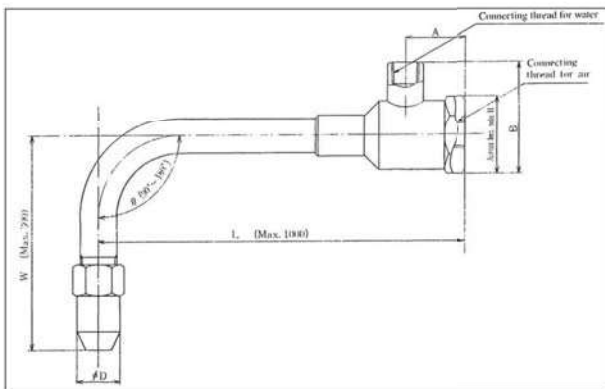

### Bent type

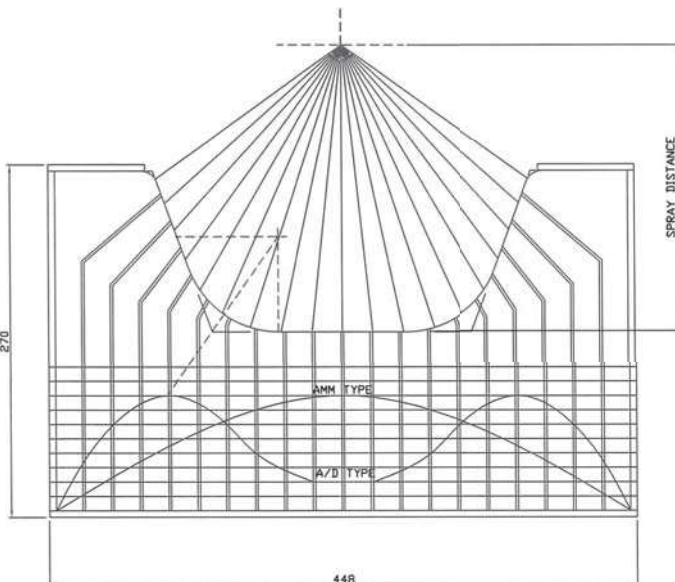
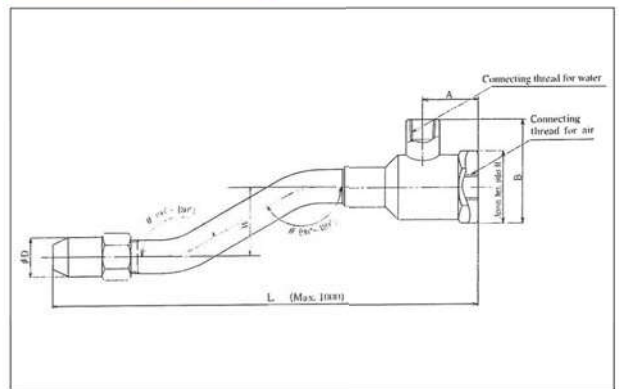

## Specification

PART NO.	WATER PRESSURE (kgf/cm <sup>2</sup> )	AIR FLOW RATE (Nm <sup>3</sup> /h)	WATER FLOW RATE (L/MIN)	SPRAY ANGLE (°)	SPRAY DISTANCE (mm)
1/4-3/8-0470AMM	2	2	2.4	70 ( )	220
1/4-3/8-0695AMM	2	2	3.6	95 ( )	220
1/4-3/8-0895AMM	2	2	5.3	95 ( )	220
1/4-3/8-0470AMM	2	2	2.4	70 ( )	175
1/4-3/8-0695AMM	2	2	3.6	95 ( )	200
1/4-3/8-0895AMM	2	2	5.3	95 ( )	200

# DESCALING NOZZLE

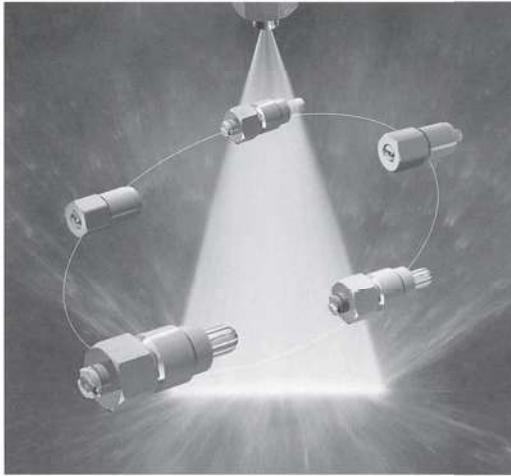

## Features

- Uniform impact force distribution.
- Excellent wear resistance.
- Consistent performance.

## Structure

- Body, Cap Filter, Tip



DESCALING ASSY

Series	spray angle				Mat-No		Volume Flow(WATER)					
	22°	26°	30°	40°	11	27	P=100bar(1450)psi			P=100bar(1450)psi		
							ℓ /min	ℓ /sec	Gal ℓ /min	ℓ /min	ℓ /sec	Gal ℓ /min
644	495	496	497	498	○	○	12.00	0.20	3.17	16.97	0.28	4.50
644	535	536	537	538	○	○	15.00	0.25	3.96	21.21	0.35	5.60
644	565	566	567	568	○	○	18.00	0.30	4.76	25.46	0.42	6.73
644	605	606	607	608	○	○	23.00	0.38	6.08	32.53	0.59	9.39
644	645	646	647	648	○	○	28.00	0.47	7.40	39.60	0.66	10.46
644	685	686	687	688	○	○	36.00	0.60	9.51	50.91	0.85	13.45
644	725	725	727	728	○	○	45.00	0.75	11.89	63.64	1.06	16.81
644	765	766	767	768	○	○	58.00	0.97	15.32	82.02	1.37	21.67
644	805	806	807	808	○	○	72.00	1.20	19.02	101.82	1.70	26.90
644	845	846	847	848	○	○	89.00	1.48	23.51	125.67	2.10	33.25
644	885	886	887	888	○	○	112.00	1.87	29.59	158.39	2.64	41.85
644	905	906	907	908	○	○	125.00	2.08	30.03	176.78	2.95	46.70
644	915	916	917	918	○	○	134.00	2.23	35.40	189.50	3.16	50.07

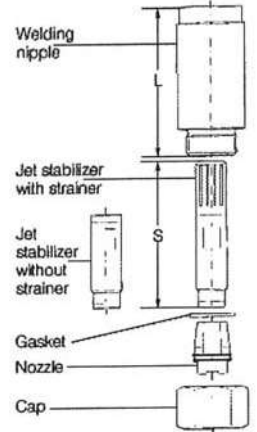

## Specification

Type (Spray angle 22°)	E Ø (mm)	A Ø (mm)
644.495	1.20	1.50
644.535	1.40	1.75
644.565	1.60	2.00
644.606	1.80	2.10
644.645	2.00	2.50
644.685	2.20	2.80
644.725	2.50	3.00
644.765	2.80	3.50
644.805	3.20	3.80
644.845	3.50	4.30
644.885	3.90	4.70

Type (Spray angle 26°)	E Ø (mm)	A Ø (mm)
644.496	1.17	1.50
644.536	1.30	1.75
644.566	1.50	2.00
644.606	1.70	2.10
644.646	1.90	2.50
644.686	2.20	2.80
644.726	2.40	3.00
644.766	2.50	3.50
644.806	3.00	3.80
644.846	3.50	4.30
644.886	3.90	4.70
644.906	4.00	5.00
644.916	4.20	5.20

Type (Spray angle 30°)	E Ø (mm)	A Ø (mm)
644.497	1.16	1.50
644.537	1.30	1.75
644.567	1.40	2.00
644.607	1.60	2.10
644.647	1.80	2.50
644.687	2.10	2.80
644.727	2.30	3.00
644.767	2.40	3.50
644.807	2.90	3.80
644.847	3.20	4.30
644.887	3.70	4.70
644.907	3.90	5.00
644.917	4.00	5.20

Type (Spray angle 30°)	E Ø (mm)	A Ø (mm)
644.498	1.11	1.50
644.538	1.20	1.75
644.568	1.20	2.00
644.608	1.50	2.10
644.648	1.60	2.50
644.688	2.00	2.80
644.728	1.90	3.00
644.768	2.30	3.50
644.808	2.70	3.80
644.848	3.00	4.30
644.888	3.40	4.70
644.908	3.70	5.00
644.918	3.80	5.20







# FLO-JET NOZZLE

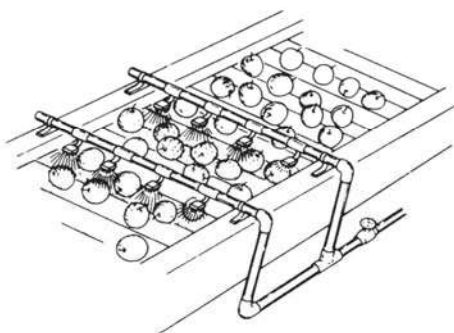
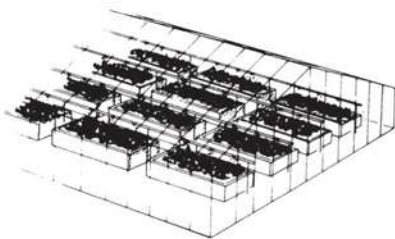
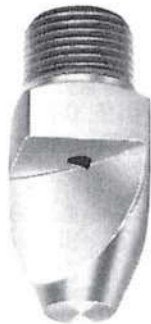

## FP Type

### Features

- Low pressure in the fan-shaped spray of a strong impact
- Large unobstructed flow passage minimizes clogging.
- spray viscosity

### Materials

- 303, 304, 316 Stainless Steel, Brass
- Other materials available upon request.

### Applications

- High wallop cleaning
- Carpet and net fabric washing
- Grease and dirt removing
- Electroplating line washing
- Fruit-vegetable washing

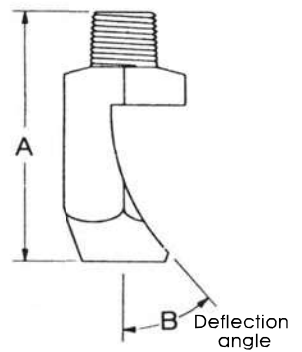

Angle	Nozzle Number	Orifice Dia. (mm)	Dimension			Capacity ℓ /min						Spray Angle				
			A	B	Specifcations	1	2	3	4	5	6	7	10	1	3	7
						kg/cm <sup>2</sup>	kg/cm <sup>2</sup>	kg/cm <sup>2</sup>	kg/cm <sup>2</sup>	kg/cm <sup>2</sup>	kg/cm <sup>2</sup>	kg/cm <sup>2</sup>	kg/cm <sup>2</sup>	kg/cm <sup>2</sup>	kg/cm <sup>2</sup>	kg/cm <sup>2</sup>
50°	¼FP5010	1.9	31	60°	15.9	2.3	3.2	3.9	4.5	5.0	5.5	6.0	7.1	34°	50°	60°
	¼FP5025	2.9	41	50°	19.1	5.6	8.0	9.8	11.3	12.6	13.8	14.9	17.9	42°	50°	59°
	¼FP5040	3.7	47	45°	19.1	9.0	12.8	15.6	18.1	20	22	24	29	39°	50°	60°
	⅜FP5040	3.7	47	45°	19.1	9.0	12.8	15.6	18.1	20	22	24	29	39°	50°	60°
	⅜FP5060	4.6	55	37°	25.4	13.5	19.2	23	27	30	33	36	43	42°	50°	63°
	½FP50100	6.0	72	40°	31.8	23	32	39	45	50	55	60	71	43°	50°	55°
	½FP50125	6.7	72	38°	31.8	28	40	49	56	63	69	75	89	38°	50°	29°
	½FP50160	7.5	72	37°	31.8	36	51	63	72	81	88	96	114	44°	50°	55°
½FP50200	8.4	72	32°	31.8	45	64	78	90	101	111	119	143	46°	50°	53°	
40°	⅜FP4040	3.7	60	35°	22.2	9.0	12.8	15.6	18.1	20	22	24	29	31°	40°	50°
	⅜FP4050	4.1	64	33°	25.4	11.3	16.0	19.5	23	25	28	30	36	31°	40°	49°
	⅜FP4060	4.5	72	33°	25.4	13.5	19.2	23	27	30	33	36	43	32°	40°	49°
	⅜FP4070	5.0	75	29°	25.4	15.8	22	27	32	35	39	42	50	32°	40°	49°
	½FP4080	5.2	77	26°	25.4	18.1	26	31	36	40	44	48	57	32°	40°	48°
	½FP4090	5.7	77	28°	25.4	20	29	35	41	45	50	54	64	34°	40°	44°
	½FP40100	6.0	87	28°	25.4	23	32	39	45	50	55	60	71	25°	40°	44°
	½FP40100	6.0	87	28°	25.4	23	32	39	45	50	55	60	71	25°	40°	44°
35°	¼FP3504	1.2	23	40°	11.1	0.90	1.3	1.6	1.8	2.0	2.2	2.4	2.9	20°	35°	41°
	¼FP3510	1.9	37	36°	15.9	2.3	3.2	3.9	4.5	5.0	5.5	6.0	7.1	18°	35°	39°
	¼FP3520	2.6	42	30°	19.1	4.5	6.4	7.8	9.0	10.1	11.1	11.9	14.3	24°	35°	40°
	⅜FP3520	2.6	43	30°	19.1	4.5	6.4	7.8	9.0	10.1	11.1	11.9	14.3	24°	35°	40°
	⅜FP3525	2.9	49	28°	19.1	5.6	8.0	9.8	11.3	12.6	13.8	14.9	17.9	24°	35°	39°
	½FP3530	3.3	52	28°	19.1	6.8	9.6	11.7	13.5	15.1	16.6	17.9	21	26°	35°	41°
	½FP3540	3.7	58	26°	22.2	9.0	12.8	15.6	18.1	20	22	24	29	28°	35°	38°
	½FP3550	4.1	64	23°	22.2	11.3	16.0	19.5	23	25	28	30	36	31°	35°	38°
	½FP3560	4.5	73	27°	25.4	13.5	19.2	23	27	30	33	36	43	29°	35°	39°
	½FP3580	5.3	81	24°	25.4	18.1	26	31	36	40	44	48	57	26°	35°	40°
25°	½FP35100	5.9	89	19°	25.4	23	32	39	45	50	55	60	71	26°	35°	40°
	½FP35160	7.5	114	23°	31.8	36	51	63	72	81	88	96	114	26°	35°	40°
	½FP35200	8.4	122	22°	31.8	45	64	78	90	101	111	119	143	25°	35°	40°
	½FP2540	3.7	65	25°	19.1	9.0	12.8	15.6	18.1	20	22	24	29	15°	25°	34°
15°	¼FP1510	1.9	48	22°	15.9		3.2	3.9	4.5	5.0	5.5	6.0	7.1		15°	23°
	¼FP1520	2.6	54	19°	15.9		6.4	7.8	9.0	10.1	11.1	11.9	14.3		15°	19°
	⅜FP1530	3.2	72	25°	19.1	6.8	9.6	11.7	13.5	15.1	16.6	17.9	21	6°	15°	24°
	⅜FP1540	3.7	92	18°	22.2	9.0	12.8	15.6	18.1	20	22	24	29	8°	15°	21°
	⅜FP1550	4.2	90	15°	22.2	11.3	16.0	19.5	23	25	28	30	36	9°	15°	20°
	½FP1560	4.6	125	14°	25.4	13.5	19.2	23	27	30	33	36	43	10°	15°	19°
	½FP1580	5.3	130	14°	25.4	18.1	26	31	36	40	44	48	57	11°	15°	18°
	½FP15100	5.9	137	14°	25.4	23	32	39	45	50	55	60	71	11°	15°	18°
½FP15200	8.4	191	14°	31.8	45	64	78	90	101	111	119	143	12°	15°	18°	

# FLO-JET NOZZLE

FLO-JET NOZZLE



## FK Type

### Features

- Wide angle deflector type
- Low impact, flat spray pattern.
- One-piece design, no cores or internal members to clog.

### Materials

- 03, 304, 316 Stainless Steel,
- Brass, and other materials available upon request.

### Applications

- Roll cooling, Metal cleaning,
- Dust control, Mold cooling
- Metal processing, Oil coating
- Parts washing, Food processing

Nozzle Number	Orifice Dia. (mm)	Dimension		Capacity ℓ /min					Spray Angle		
		Hex.	L (mm)	1 kg/cm <sup>2</sup>	1.5 kg/cm <sup>2</sup>	2 kg/cm <sup>2</sup>	3 kg/cm <sup>2</sup>	4 kg/cm <sup>2</sup>	0.5 kg/cm <sup>2</sup>	1.5 kg/cm <sup>2</sup>	4 kg/cm <sup>2</sup>
1/8FK0.25	0.41	11.1	24	0.11	0.14	0.16	0.20	0.23		83°	117°
1/8FK0.50	0.60	11.1	24	0.23	0.28	0.32	0.39	0.45		89°	122°
1/8FK0.75	0.71	11.1	24	0.34	0.41	0.48	0.59	0.68		106°	125°
1/8FK1	0.84	11.1	24	0.45	0.55	0.64	0.78	0.90		109°	128°
1/8FK1.5	1.0	11.1	24	0.68	0.83	0.96	1.2	1.4	73°	108°	125°
1/8FK2	1.2	11.1	25	0.90	1.1	1.3	1.6	1.8	83°	113°	129°
1/8FK2.5	1.3	11.1	25	1.1	1.4	1.6	2.0	2.3	98°	122°	133°
1/8FK3	1.4	11.1	25	1.4	1.7	1.9	2.3	2.7	86°	112°	126°
1/8FK4	1.7	11.1	25	1.8	2.2	2.6	3.1	3.6	97°	123°	132°
1/8FK5	1.9	11.1	25	2.3	2.8	3.2	3.9	4.5	114°	128°	142°
1/8FK7.5	2.3	11.1	25	3.4	4.1	4.8	5.9	6.8	101°	119°	134°
1/8FK10	2.6	11.1	25	4.5	5.5	6.4	7.8	9.0	115°	133°	145°
1/8FK12	2.9	11.1	25	5.4	6.6	7.7	9.4	10.9	128°	139°	153°
1/8FK15	3.3	14.3	31	6.8	8.3	9.6	11.7	13.6	98°	113°	123°
1/8FK18	3.6	14.3	31	8.1	10.0	11.5	14.1	16.3	106°	120°	131°
1/8FK20	3.7	14.3	31	9.0	11.1	12.8	15.7	18.1	110°	122°	133°
1/4FK2	1.2	14.3	31	0.90	1.1	1.3	1.6	1.8	82°	111°	128°
1/4FK2.5	1.3	14.3	31	1.1	1.4	1.6	2.0	2.3	98°	122°	133°
1/4FK3	1.4	14.3	31	1.4	1.7	1.9	2.3	2.7	86°	112°	126°
1/4FK5	1.9	14.3	31	2.3	2.8	3.2	3.9	4.5	114°	128°	142°
1/4FK7.5	2.3	14.3	31	3.4	4.1	4.8	5.9	6.8	101°	119°	134°
1/4FK10	2.6	14.3	31	4.5	5.5	6.4	7.8	9.0	115°	133°	145°
1/4FK15	3.3	14.3	34	6.8	8.3	9.6	11.7	13.6	98°	113°	123°
1/4FK18	3.6	14.3	34	8.1	10.0	11.5	14.1	16.3	106°	120°	131°
1/4FK20	3.7	14.3	34	9.0	11.1	12.8	15.7	18.1	110°	122°	133°
1/4FK22	4.0	14.3	34	9.9	12.2	14.0	17.2	19.9	113°	125°	136°
1/4FK24	4.1	14.3	34	10.8	13.3	15.3	18.8	22	115°	131°	144°
1/4FK27	4.4	14.3	34	12.2	14.9	17.2	21	24	119°	135°	148°
3/8FK30	4.6	17.5	44	13.5	16.6	19.2	23	27	100°	110°	121°
3/8FK35	5.0	17.5	44	15.8	19.3	22	27	32	105°	118°	128°
3/8FK40	5.3	17.5	44	18.1	22	26	31	36	111°	126°	136°
3/8FK45	5.6	17.5	44	20	25	29	35	41	115°	130°	140°
1/2FK40	5.3	22.2	51	18.1	22	26	31	36	111°	126°	136°
1/2FK50	6.0	22.2	51	23	28	32	39	45	117°	131°	140°
1/2FK60	6.5	22.2	51	27	33	38	47	54	120°	134°	142°
1/2FK70	7.1	22.2	51	32	39	45	55	63	123°	137°	146°
1/2FK80	7.5	22.2	51	36	44	51	63	72	127°	138°	149°
3/4FK90	8.0	28.6	56	41	50	57	70	81	120°	133°	140°
3/4FK100	8.4	28.6	56	45	55	64	78	90	123°	136°	145°
3/4FK110	8.8	28.6	56	50	61	70	86	99	125°	138°	148°
3/4FK120	9.3	28.6	56	54	66	77	94	109	128°	143°	153°
3/4FK180	11.5	38.1	65	81	100	115	141	163	124°	133°	139°
3/4FK210	12.3	38.1	65	95	116	134	164	190	128°	139°	145°
1FK300	14.7	44.5	87	135	166	192	235	270	110°	128°	135°
1FK450	17.9	47.6	92	205	250	285	350	405	118°	132°	138°



FK Type

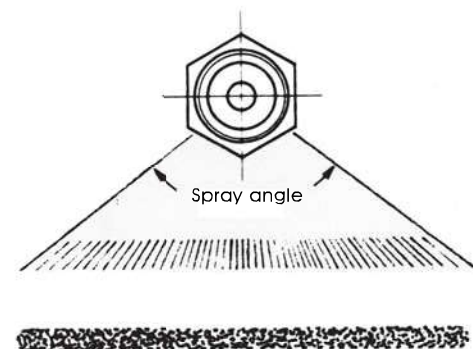
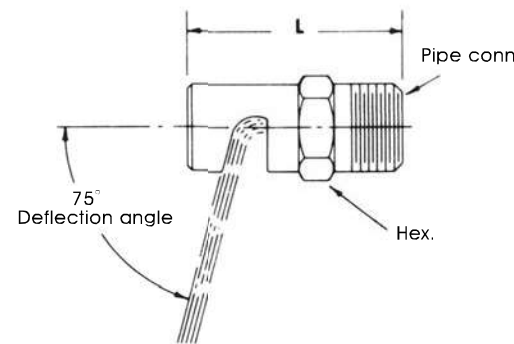

Wide angle flat spray type

# SOLID-JET NOZZLE (Wire & Felt Cleaning)

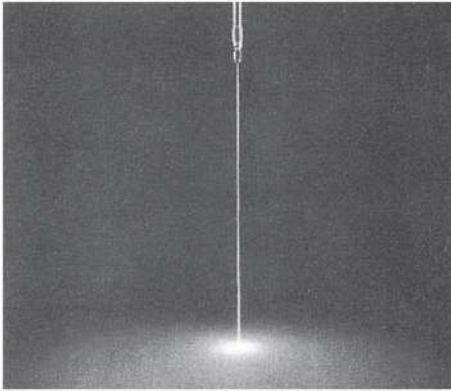

## MCP TYPE

### Features

-Extra fine solid stream with high impact cutting force

### Structure

-One-piece structure with ceramic orifice inserted

### Material

-Spray orifice: Ceramics

-Metal parts: Brass or 303 Stainless steel

### Applications

-Cleaning: High pressure jet cleaning, wire and felt parts of paper making machines, vehicles, returnable containers, machinery, parts, etc.

-Trimming: Paper making, asbestos pate, etc.

Nozzle Number	Capacity ℓ /min												Free Pass. Dia.	Strainer Mesh Size
	10 kg/cm <sup>2</sup>	20 kg/cm <sup>2</sup>	25 kg/cm <sup>2</sup>	30 kg/cm <sup>2</sup>	35 kg/cm <sup>2</sup>	40 kg/cm <sup>2</sup>	45 kg/cm <sup>2</sup>	50 kg/cm <sup>2</sup>	65 kg/cm <sup>2</sup>	80 kg/cm <sup>2</sup>	100 kg/cm <sup>2</sup>	150 kg/cm <sup>2</sup>		
1/8 MCP 25☆ W	1.43	2.02	2.25	2.47	2.67	2.85	3.03	3.19	3.64	4.03	4.51	5.52	0.8	50
1/8 MCP 31☆ W	1.78	2.52	2.82	3.09	3.34	3.57	3.78	3.99	4.55	5.05	5.64	6.91	0.9	50
1/8 MCP 37☆	2.14	3.03	3.39	3.71	4.01	4.28	4.54	4.79	5.46	6.06	6.77	8.30	1.0	-
1/8 MCP 43☆	2.50	3.54	3.96	4.33	4.68	5.00	5.30	5.59	6.37	7.06	7.91	9.67	1.1	-
1/8 MCP 49☆	2.86	4.04	4.52	4.94	5.34	5.71	6.06	6.38	7.28	8.07	9.04	11.1	1.2	-
1/8 MCP 56☆	3.22	4.54	5.08	5.56	6.01	6.42	6.81	7.18	8.19	9.08	10.2	12.4	1.2	-
1/8 MCP 62☆	3.57	5.05	5.65	6.18	6.68	7.14	7.57	7.98	9.10	10.1	11.3	13.8	1.3	-
1/8 MCP 68☆	3.93	5.55	6.21	6.80	7.35	7.85	8.33	8.79	10.0	11.1	12.4	15.2	1.4	-
1/8 MCP 74☆	4.29	6.06	6.78	7.42	8.01	8.56	9.09	9.58	10.9	12.1	13.6	16.6	1.4	-
1/8 MCP 80☆	4.65	6.56	7.35	8.04	8.68	9.28	9.85	10.4	11.8	13.1	14.7	18.0	1.5	-
1/8 MCP 87☆	5.00	7.07	7.91	8.66	9.35	10.0	10.6	11.2	12.8	14.1	15.8	19.4	1.6	-
1/8 MCP 93☆	5.36	7.58	8.48	9.28	10.0	10.7	11.4	12.0	13.7	15.2	17.0	20.8	1.6	-
1/8 MCP 99☆	5.72	8.08	9.04	9.89	10.7	11.4	12.1	12.8	14.6	16.2	18.1	22.1	1.7	-
1/8 MCP 111☆	6.43	9.09	10.2	11.1	12.0	12.9	13.6	14.4	16.4	18.2	20.3	24.9	1.8	-
1/8 MCP 124☆	7.15	10.1	11.3	12.4	13.4	14.3	15.1	16.0	18.2	20.2	22.6	27.7	1.9	-
1/8 MCP 136☆	7.85	11.1	12.4	13.6	14.7	15.7	16.7	17.6	20.0	22.2	24.8	30.4	2.0	-
1/8 MCP 148☆	8.57	12.1	13.6	14.8	16.0	17.1	18.2	19.2	21.8	24.2	27.1	33.2	2.0	-
1/8 MCP 161☆	9.28	13.1	14.7	16.1	17.4	18.6	19.7	20.8	23.7	26.2	29.3	35.9	2.1	-
1/8 MCP 173☆	9.99	14.1	15.8	17.3	18.7	20.0	21.2	22.4	25.5	28.3	31.6	38.7	2.2	-
1/8 MCP 186☆	10.7	15.2	16.9	18.6	20.0	21.4	22.7	24.0	27.3	30.3	33.9	41.5	2.3	-
1/8 MCP 198☆	11.4	16.2	18.1	19.8	21.4	22.8	24.2	25.5	29.1	32.3	36.1	44.2	2.4	-
1/8 MCP 210☆	12.1	17.2	19.2	21.0	22.7	24.3	25.7	27.1	30.9	34.3	38.4	47.0	2.4	-
1/4 MCP 223☆	12.9	18.2	20.3	22.3	24.0	25.7	27.3	28.7	32.8	36.3	40.6	49.8	2.5	-
1/4 MCP 247☆	14.3	20.2	22.6	24.7	26.7	28.6	30.3	31.9	36.4	40.4	45.2	55.3	2.6	-
1/4 MCP 272☆	15.7	22.2	24.8	27.2	29.4	31.4	33.3	35.1	40.0	44.4	49.7	60.8	2.7	-
1/4 MCP 297☆	17.1	24.2	27.1	29.7	32.1	34.3	36.3	38.3	43.7	48.5	54.2	66.4	2.9	-
1/4 MCP 322☆	18.6	26.3	29.4	32.2	34.7	37.1	39.4	41.5	47.3	52.5	58.7	71.9	3.0	-
1/4 MCP 346☆	20.0	28.3	31.6	34.6	37.4	40.0	42.4	44.7	51.0	56.5	63.2	77.4	3.1	-
1/4 MCP 371☆	21.4	30.3	33.9	37.1	40.1	42.8	45.4	47.9	54.6	60.6	67.6	82.9	3.2	-
1/4 MCP 396☆	22.8	32.3	36.1	39.6	42.7	45.7	48.5	51.1	58.2	64.6	72.2	88.5	3.3	-
1/4 MCP 420☆	24.3	34.3	38.4	42.0	45.4	48.5	51.5	54.3	61.9	68.7	76.8	94.0	3.4	-
1/4 MCP 445☆	25.7	36.3	40.6	44.5	48.51	51.4	54.5	57.5	65.5	72.7	81.3	99.5	3.5	-
1/4 MCP 470☆	27.1	38.4	42.9	47.0	50.7	54.3	57.5	60.7	69.2	76.7	85.8	105	3.6	-
1/4 MCP 495☆	28.6	40.4	45.1	49.5	53.4	57.1	60.6	63.8	72.8	80.8	90.3	111	3.7	-
1/4 MCP 519☆	30.0	42.4	47.4	51.9	56.1	60.0	63.6	67.0	76.4	84.8	94.8	116	3.8	-
1/4 MCP 544☆	31.4	44.4	49.7	54.4	58.8	62.8	66.6	70.2	80.1	88.8	99.3	122	3.9	-
3/8 MCP 569☆	32.8	46.4	51.9	56.9	61.4	65.7	69.7	73.4	83.7	92.9	104	127	4.0	-
3/8 MCP 594☆	34.3	48.5	54.2	59.4	64.1	68.5	72.7	76.6	87.4	96.9	108	133	4.1	-
3/8 MCP 618☆	36.7	50.5	56.4	61.8	66.8	71.4	75.7	79.8	91.0	101	113	138	4.2	-
3/8 MCP 643☆	37.1	52.5	58.7	64.3	69.4	74.2	78.7	83.0	94.6	105	117	144	4.2	-
3/8 MCP 668☆	38.5	54.5	60.9	66.8	72.1	77.1	81.8	86.2	98.3	109	122	149	4.3	-
3/8 MCP 692☆	40.0	56.5	63.2	69.2	74.8	80.0	84.8	89.4	102	113	126	155	4.4	-
3/8 MCP 717☆	41.4	58.6	65.5	71.7	77.5	82.8	87.8	92.6	106	117	131	160	4.5	-
3/8 MCP 742☆	42.8	60.6	67.7	74.2	80.1	85.7	90.9	95.8	109	121	135	166	4.6	-
3/8 MCP 767☆	44.3	62.6	70.0	76.7	82.8	88.5	93.9	99.0	113	125	140	171	4.6	-
3/8 MCP 791☆	45.7	64.6	72.2	79.1	85.8	91.4	96.9	102	117	129	145	177	4.7	-
3/8 MCP 816☆	47.1	66.6	74.5	81.6	88.1	94.2	99.9	105	120	133	149	183	4.8	-
3/8 MCP 841☆	48.5	68.6	76.7	84.1	90.8	97.1	103	109	124	137	154	188	4.9	-
3/8 MCP 866☆	50.0	70.7	79.0	86.6	93.5	99.9	106	112	127	141	158	194	4.9	-
3/8 MCP 890☆	51.4	72.7	81.3	89.0	96.2	103	109	115	131	145	163	199	5.0	-
3/8 MCP 915☆	52.8	74.7	83.5	91.5	98.8	106	112	118	135	149	167	205	5.1	-
3/8 MCP 940☆	54.3	76.7	85.8	94.0	102	109	115	121	138	153	172	210	5.1	-
3/8 MCP 964☆	55.7	78.7	88.0	96.4	104	111	118	125	142	158	176	216	5.2	-
3/8 MCP 989☆	57.1	80.8	90.3	98.9	107	114	121	128	146	162	181	221	5.3	-
3/8 MCP 1014☆	58.5	82.8	92.6	101	110	117	124	131	149	166	185	227	5.3	-
3/8 MCP 1039☆	60.0	84.8	94.8	104	112	120	127	134	153	170	190	232	5.4	-

☆ = Nozzle Material

-Add B to Brass  
-Add S303 to Stainless steel

(예) 1/8MCP 25 B W

(예) 1/8MCP 25 S303 W

W=Strainer

-W=Strainer W (with Strainer) - (without Strainer)

-Models that do not appear W available upon request also



MCM, MCTM TYPE (Paper trimming)



MCP TYPE



MCRP TYPE (wire high pressure cleaning)

# SOLID-JET NOZZLE

## MCP SERIES

1/8MCP

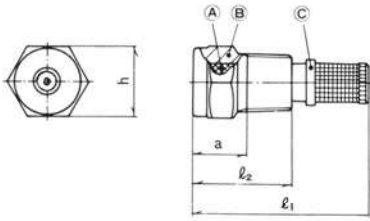

1/4MCP or higher

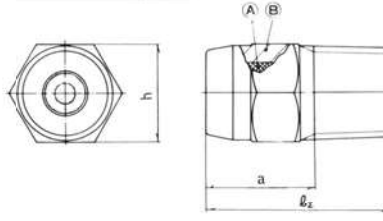

Pipe Conn. Size	Dimensions (mm)				Weight(g)	
	l <sub>1</sub>	l <sub>2</sub>	h	a	B	SUS
1/8MCP	29.5	16.5	12	9.5	7.8(10)	7.1(9)
1/4MCP	-	26.0	14	15.5	21	19.5
3/8MCP	-	30.0	19	19.0	40	38

\* ( ) 안의 with strainer weight 시의 중량임

Nozzle Number		Capacity ℓ/min							Free Pass. Dia.
1/8" mounting aperture	1/4" mounting aperture	3 kg/cm <sup>2</sup>	5 kg/cm <sup>2</sup>	7 kg/cm <sup>2</sup>	10 kg/cm <sup>2</sup>	15 kg/cm <sup>2</sup>	20 kg/cm <sup>2</sup>	30 kg/cm <sup>2</sup>	
1/8 MCRP 06☆	1/4 MCRP 06☆	0.24	0.30	0.36	0.43	0.53	0.61	0.74	0.5
1/8 MCRP 09☆	1/4 MCRP 09☆	0.34	0.44	0.52	0.62	0.76	0.88	1.07	0.6
1/8 MCRP 12☆	1/4 MCRP 12☆	0.46	0.59	0.70	0.84	1.03	1.19	1.45	0.7
1/8 MCRP 15☆	1/4 MCRP 15☆	0.60	0.77	0.91	1.09	1.33	1.54	1.89	0.8
1/8 MCRP 20☆	1/4 MCRP 20☆	0.76	0.98	1.15	1.38	1.69	1.95	2.39	0.9
1/8 MCRP 24☆	1/4 MCRP 24☆	0.94	1.21	1.43	1.71	2.09	2.42	2.96	1.0
1/8 MCRP 29☆	1/4 MCRP 29☆	1.13	1.46	1.73	2.07	2.54	2.93	3.59	1.1
1/8 MCRP 35☆	1/4 MCRP 35☆	1.35	1.74	2.06	2.46	3.01	3.48	4.26	1.2
1/8 MCRP 41☆	1/4 MCRP 41☆	1.58	2.04	2.42	2.89	3.54	4.09	5.01	1.3
1/8 MCRP 47☆	1/4 MCRP 47☆	1.83	2.37	2.80	3.35	4.10	4.74	5.80	1.4
1/8 MCRP 54☆	1/4 MCRP 54☆	2.11	2.72	3.22	3.85	4.72	5.44	6.67	1.5
1/8 MCRP 70☆	1/4 MCRP 70☆	2.71	3.50	4.14	4.95	6.06	7.00	8.57	1.7
1/8 MCRP 97☆	1/4 MCRP 97☆	3.75	4.84	5.72	6.84	8.38	9.67	11.80	2.0

## MCRP SERIES

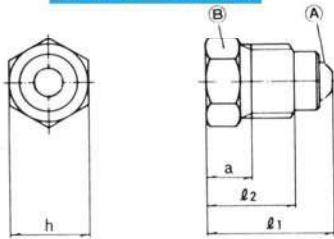

Pipe Conn. Size	Dimensions (mm)				Weight (g)
	l <sub>1</sub>	l <sub>2</sub>	h	a	
1/8MCP	18	13	12	9	7.0
1/4MCP	22	15.5	14	9.5	15.0

- (A) Ceramic or Tungsten carbide
- (B) Body체
- (C) Metal Adaptor
- (D) Metal Strainer

## MCM, MCTM SERIES

중량 (gr)	B	SUS
	55	50

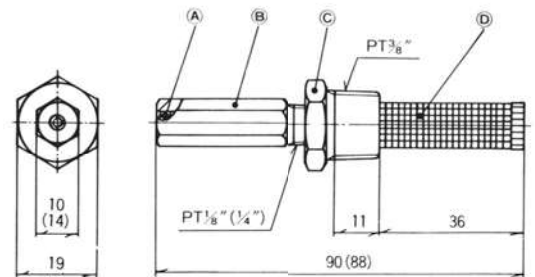

\* Dimensions in ( ) are 1.3, 6.16, 1.9, 2.3, 2.6, 3.0

Nozzle Number		Capacity ℓ/min						Free Pass. Dia.	Strainer Mesh Size
CERAMIC TIP	TC TIP	5 kg/cm <sup>2</sup>	10 kg/cm <sup>2</sup>	20 kg/cm <sup>2</sup>	30 kg/cm <sup>2</sup>	40 kg/cm <sup>2</sup>	50 kg/cm <sup>2</sup>		
3/8 MCM 01☆W	3/8 MCTM 01☆W	0.10	0.14	0.19	0.23	0.27	0.30	0.3	150
3/8 MCM 02☆W	3/8 MCTM 02☆W	0.17	0.24	0.34	0.41	0.47	0.52	0.4	150
3/8 MCM 04☆W	3/8 MCTM 04☆W	0.25	0.35	0.49	0.60	0.68	0.76	0.5	100
3/8 MCM 05☆W	3/8 MCTM 05☆W	0.36	0.51	0.71	0.86	0.99	1.10	0.6	100
3/8 MCM 07☆W	3/8 MCTM 07☆W	0.49	0.68	0.96	1.17	1.34	1.54	0.7	50
3/8 MCM 09☆W	3/8 MCTM 09☆W	0.65	0.90	1.26	1.53	1.75	1.95	0.8	50
3/8 MCM 11☆W	3/8 MCTM 11☆W	0.78	1.09	1.52	1.84	2.11	2.64	0.9	50
3/8 MCM 13☆W	3/8 MCTM 13☆W	0.97	1.34	1.88	2.28	2.61	2.91	1.0	50
3/8 MCM 16☆W	3/8 MCTM 16☆W	1.17	1.63	2.27	2.75	3.16	3.51	1.1	50
3/8 MCM 19☆W	3/8 MCTM 19☆W	1.39	1.94	2.70	3.28	3.76	4.18	1.2	50
3/8 MCM 23☆W	3/8 MCTM 23☆W	1.63	2.27	3.17	3.85	4.41	4.91	1.3	50
3/8 MCM 26☆W	3/8 MCTM 26☆W	1.89	2.64	3.68	4.46	5.17	5.69	1.4	50
3/8 MCM 30☆W	3/8 MCTM 30☆W	2.17	3.03	4.22	5.12	5.88	6.54	1.5	50

# BRUSH HEADER



## SJ-ND

### Features

-Flat Spray for Shower header

### Material

-303, Stainless Steel, Brass, Other materials available upon request

### Applications

-Dewatering

Nozzle Number	Thread Size	Capacity ( ℓ / min)										Spray Angle			
		0.5kg/cm <sup>2</sup>	1kg/cm <sup>2</sup>	1.5kg/cm <sup>2</sup>	2.0kg/cm <sup>2</sup>	2.5kg/cm <sup>2</sup>	3.0kg/cm <sup>2</sup>	4.0kg/cm <sup>2</sup>	5kg/cm <sup>2</sup>	6kg/cm <sup>2</sup>	7kg/cm <sup>2</sup>	1kg/cm <sup>2</sup>	3kg/cm <sup>2</sup>	5kg/cm <sup>2</sup>	7kg/cm <sup>2</sup>
M-ND 4	3/8"	1.4	2.1	2.6	3.0	3.3	3.6	4.0	4.3	4.7	5	38	45	50	60
M-ND 8	3/8"	2.7	3.8	4.7	5.5	6.3	6.8	8	9	9.6	10.3	42	45	54	55

## SJ-FS

### Features

-Flat Spray for Shower header

### Material

-303, 304Stainless Steel,  
Other materials available upon request

### Applications

-Showers for Paper making

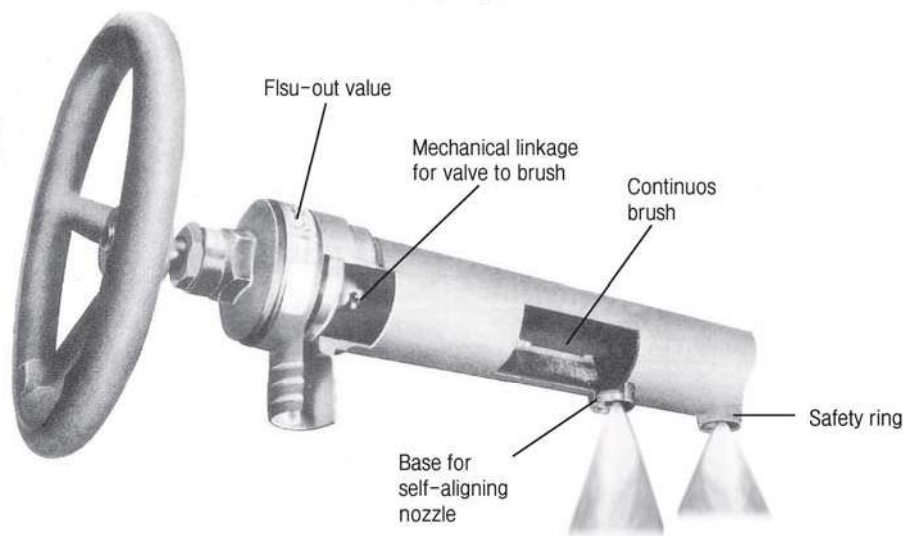

Nozzle Number	Orifice Dia (mm)	Capacity ( ℓ / min)						Spray Angle		
		1.5kg/cm <sup>2</sup>	3kg/cm <sup>2</sup>	5kg/cm <sup>2</sup>	7kg/cm <sup>2</sup>	10kg/cm <sup>2</sup>	20kg/cm <sup>2</sup>	0°	30°	60°
SJ-FS08	0.8	0.8	0.5	0.65	0.77	0.92	1.3	●		
SJ-FS10	1.0	1.0	0.9	1.2	1.5	1.8	2.4	●		
SJ-FS12	1.2	1.2	1.3	1.63	2	2.4	3.5	●		
SJ-FS15	1.5	1.5	1.7	2.2	2.6	3.1	4.4	●	●	●
SJ-FS20	2.0	2.0	3	3.9	5	6	8.4	●	●	●
SJ-FS25	2.5	2.5	5	6.5	7.6	9	13	●	●	●
SJ-FS30	3.0	3.0	8	10.3	12	14.3	20	●	●	●
SJ-FS40	4.0	4.0	12.5	16	19	22.7	32	●	●	●

# PJ/P fine atomizing

PJ/P

## Design features

- High energy efficiency
- One-piece, compact construction
- No whirl vanes or internal parts
- Dewatering
- 1/8" or 1/4" male connection
- 200-mesh screen or 10micron paper filter optional

Applications : Humidifying, sterilization, odor removal, mist spraying

## Spray characteristics

- Finest fog of any direct pressure nozzle
- Produces high percentage of droplets under 50microns
- Spray pattern: Cone-Shaped Fog
- Spray angle: 90°
- Flow rates: 0.0367 to 5.34 l /m

PJ



P



Fog

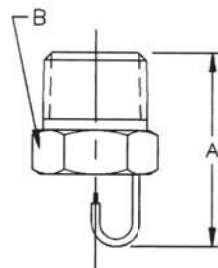

PJ Male

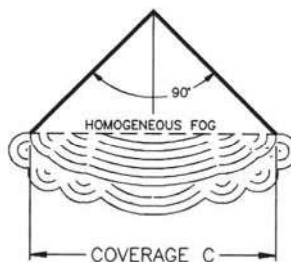

Fog Pattern

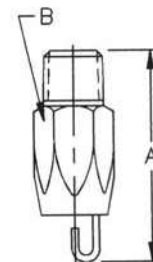

P Male

## Flow Rates and Dimensions

Impingement, 90° Spray Angle, 1/8" or 1/4" Pipe Sizes, BSP or NPT

### DISC JET SPRAY NOZZLE

Male Pipe Size	Nozzle Number	K Factor	Capacity ( l /min) kg/cm <sup>2</sup>								Orifice Dia. (mm)	Dimension. (mm)			Wt. (g)
			2 kg/cm <sup>2</sup>	3 kg/cm <sup>2</sup>	5 kg/cm <sup>2</sup>	10 kg/cm <sup>2</sup>	20 kg/cm <sup>2</sup>	30 kg/cm <sup>2</sup>	50 kg/cm <sup>2</sup>	70 kg/cm <sup>2</sup>		A	B	C	
1/8	PJ8	0.0259	-	-	0.0580	0.0820	0.116	0.142	0.183	0.217	0.203	19.1	11.1	254	7
	PJ10	0.0387	-	0.0671	0.0866	0.123	0.173	0.212	0.274	0.324	0.254				
~	PJ12	0.0254	-	0.0908	0.117	0.166	0.234	0.287	0.371	0.439	0.305				
1/4	PJ15	0.0843	0.119	0.146	0.189	0.267	0.377	0.462	0.596	0.705	0.381				

### ● P

Male Pipe Size	Nozzle Number	K Factor	Capacity ( l /min) kg/cm <sup>2</sup>								Orifice Dia. (mm)	Dimension. (mm)			Wt. (g)	
			1 kg/cm <sup>2</sup>	2 kg/cm <sup>2</sup>	3 kg/cm <sup>2</sup>	5 kg/cm <sup>2</sup>	7 kg/cm <sup>2</sup>	10 kg/cm <sup>2</sup>	20 kg/cm <sup>2</sup>	30 kg/cm <sup>2</sup>		A	B	C		
1/4	P20	0.153	0.153	0.216	0.264	0.341	0.404	0.483	0.683	0.836	0.508	50.8	16.0	610	57	
	P24	0.228	0.228	0.322	0.395	0.510	0.603	0.721	1.02	1.25	0.610					310
	P28	0.296	0.296	0.419	0.513	0.662	0.784	0.937	1.32	1.62	0.711					380
	P32	0.410	0.410	0.580	0.710	0.917	1.09	1.30	1.83	2.25	0.813					460
	P40	0.638	0.638	0.902	1.11	1.43	1.69	2.02	2.85	3.49	1.02					530
	P48	0.912	0.912	1.29	1.58	2.04	2.41	2.88	4.08	4.99	1.22					690
	P54	1.21	1.21	1.71	2.09	2.70	3.20	3.82	5.40	6.62	1.37					760
	P66	1.71	1.71	2.42	2.96	3.82	4.52	5.40	7.364	9.36	1.68					910
	P80	2.46	2.46	3.48	4.26	5.50	6.51	7.78	11.0	13.5	2.03					1200
	P120	5.54	5.54	7.83	9.59	12.4	14.7	17.5	24.8	30.3	3.05					1500

$$Flow\ Rate(l/min) = K \sqrt{bar}$$

Standard : Brass, 303 Stainless Steel and 316 Stainless Steel. See chart on page 17 for complete list.  
Material

# FULL JET NOZZLE

**TG Type** Design Pressure : 0.7kg/cm<sup>2</sup>

### Features

- Round spray pattern
- Uniform distribution over a wide range of flow rates and pressures

### Materials

- Standard materials are Brass, 303 Stainless Steel

### Applications

- Parts washing, Cooling, and so on.



T  
FEMALE BODY  
OR



TT  
MALE BODY



TIP RETAINER

Nozzle Number		Tip Number	Orifice Dia. (mm)	Screen Mesh	Capacity (ℓ / min)											Spray Angle		
Type T Female	Type TT Female				0.7 kg/cm <sup>2</sup>	1 kg/cm <sup>2</sup>	1.5 kg/cm <sup>2</sup>	2 kg/cm <sup>2</sup>	3 kg/cm <sup>2</sup>	4 kg/cm <sup>2</sup>	6 kg/cm <sup>2</sup>	7 kg/cm <sup>2</sup>	10 kg/cm <sup>2</sup>	15 kg/cm <sup>2</sup>	20 kg/cm <sup>2</sup>	1.5 kg/cm <sup>2</sup>	3 kg/cm <sup>2</sup>	7 kg/cm <sup>2</sup>
1/4TG0.3	1/4TTG0.3	TG0.3	0.5	100	..	..	0.16	0.19	0.23	0.28	0.32	0.36	0.45	0.49	0.60	50°	58°	61°
1/4TG0.4	1/4TTG0.4	TG0.4	0.56	100	..	..	0.22	0.26	0.30	0.37	0.42	0.49	0.61	0.68	0.83	56°	60°	63°
1/4TG0.5	1/4TTG0.5	TG0.5	0.6	100	..	0.23	0.27	0.33	0.38	0.45	0.53	0.61	0.72	0.83	1.02	56°	60°	63°
1/4TG0.6	1/4TTG0.6	TG0.6	0.68	100	..	0.28	0.32	0.38	0.45	0.57	0.64	0.72	0.87	1.02	1.25	54°	59°	62°
1/4TG0.7	1/4TTG0.7	TG0.7	0.76	100	..	0.33	0.38	0.45	0.53	0.64	0.76	0.83	1.02	1.17	1.44	54°	60°	63°
1/4TG1	1/4TTG1	TG1	0.91	*	..	0.45	0.53	0.64	0.72	0.87	0.98	1.14	1.36	1.51	1.82	58°	59°	53°
1/4TG2	1/4TTG2	TG2	1.2	*	0.76	0.91	1.06	1.29	1.44	1.74	2.00	2.23	2.91	2.99	3.63	50°	50°	46°
1/4TG3	1/4TTG3	TG3	1.6	*	1.14	1.36	1.59	1.89	2.16	2.61	2.99	3.33	4.20	4.50	5.30	65°	65°	59°
1/4TG3.5	1/4TTG3.5	TG3.5	1.7	*	1.32	1.59	1.82	2.10	2.54	3.07	3.48	3.80	4.90	5.30	6.40	50°	50°	46°
1/4TG5	1/4TTG5	TG5	2.1	*	1.89	2.27	2.61	3.10	3.59	4.50	4.90	5.70	6.80	7.60	9.10	65°	65°	59°
1/4TG6.5	1/4TTG6.5	TG6.5	2.4	*	2.46	2.95	3.37	4.20	4.90	5.70	6.40	7.20	8.70	9.80	11.7	50°	50°	46°
1/4TG10	1/4TTG10	TG10	3.2	*	3.8	4.9	5.30	6.40	7.20	9.10	10.2	11.4	13.6	15.1	18.2	67°	67°	61°

Ordering info : (Ex) Stainless steel Male - 1/4TT-SS+5  
 Brass Female - 1/4T+TG-5  
 Tip only Stainless steel - TG-SS5



**TG**  
Spray Nozzle Tip



### DIMENSIONS & WEIGHTS

Nozzle Number	Max. Length mm	Max. Hex mm	Weight
1/4T+TG	48.5	20.6	0.07
1/4TT+TG	48.5	20.6	0.07

## WIDE ANGLE FULL CONE SPRAY TIP



TG-W Type

120°

**TGW Type** Design Pressure : 0.7kg/cm<sup>2</sup>

### Features

- Wide Round spray pattern
- Uniform distribution over a wide range of flow rates and pressures

Materials : Standard materials are Stainless Steel

### Applications

- Foam break-up
- Gas scrubbing, washing, cooling
- Washing/rinsing

Nozzle Number		Tip Number	Orifice Dia. (mm)	Capacity (ℓ / min)								Spray Angle					
Type T Female	Type TT Female			0.3 kg/cm <sup>2</sup>	0.5 kg/cm <sup>2</sup>	1 kg/cm <sup>2</sup>	1.5 kg/cm <sup>2</sup>	2 kg/cm <sup>2</sup>	3 kg/cm <sup>2</sup>	4 kg/cm <sup>2</sup>	5 kg/cm <sup>2</sup>	6 kg/cm <sup>2</sup>	0.3 kg/cm <sup>2</sup>	0.7 kg/cm <sup>2</sup>	3 kg/cm <sup>2</sup>	5 kg/cm <sup>2</sup>	
1/4TG-SS2.8W	1/4TTG-SS2.8W	TG-SS2.8W	1.4			1.2	1.5	1.7	2.0	2.3	2.5	2.7			120°	120°	102°
1/4TG-SS4.3W	1/4TTG-SS4.3W	TG-SS4.3W	1.9			1.9	2.3	2.6	3.1	3.5	3.9	4.2			120°	120°	102°
1/4TG-SS5.6W	1/4TTG-SS5.6W	TG-SS5.6W	2.0		1.8	2.5	3.0	3.4	4.0	4.6	5.0	5.5			120°	120°	102°
1/4TG-SS8W	1/4TTG-SS8W	TG-SS8W	2.5		2.6	3.5	4.2	4.8	5.7	6.5	7.2	7.8			120°	120°	103°
1/4TG-SS10W	1/4TTG-SS10W	TG-SS10W	2.8	2.6	3.3	4.4	5.3	6.0	7.2	8.1	9.0	9.7	112°		120°	120°	103°
1/4TG-SS12W	1/4TTG-SS12W	TG-SS12W	3.3	3.1	3.9	5.3	6	7.2	8.6	9.8	10.8	11.7	114°		120°	120°	103°

Ordering info : (Ex) Stainless steel Male - 1/4TT-SS+TG-SS5.6W  
 Brass Body - 1/4T+TG-SS5.6W 2323

# FULL CONE NOZZLE

FULL CONE NOZZLE

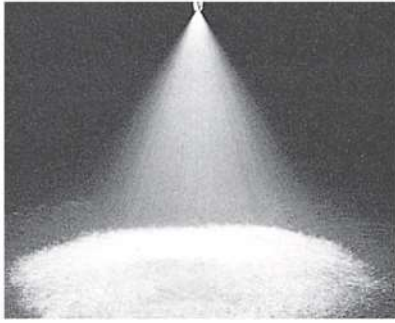

## R/RR F/FF TYPE

### Features

- Solid cone-shaped spray pattern with round impact area.
- Uniform distribution over a wide range of flow rates and pressures.
- Medium- to large-sized drops.
- Removable internal parts for easy inspection and cleaning.

### Materials

- 303, 304, 316 Stainless Steel, Brass, PVC
- Other materials available upon request

### Applications

- Cooling, Chemical processing,
- Dust control, Fire suppression/prevention
- Gas scrubbing, washing and cooling

(60°~90°)



Type R  
Female Separable Type



Type RR  
Male Separable Type



Type FF  
Male One-piece Type



Type F  
Female One-piece Type

Nozzle Number		Orifice Dia (mm)	Capacity ( ℓ / min)										Spray Angle		
Conn F	Conn M		0.5 kg/cm <sup>2</sup>	1 kg/cm <sup>2</sup>	1.5 kg/cm <sup>2</sup>	2 kg/cm <sup>2</sup>	3 kg/cm <sup>2</sup>	4 kg/cm <sup>2</sup>	5 kg/cm <sup>2</sup>	6 kg/cm <sup>2</sup>	7 kg/cm <sup>2</sup>	10 kg/cm <sup>2</sup>	0.5 kg/cm <sup>2</sup>	1.5 kg/cm <sup>2</sup>	5 kg/cm <sup>2</sup>
¼R1	¼RR1	0.89													
¼R1.5	¼RR1.5	1.2	0.49	0.67	0.80	0.92	1.1	1.3	1.4	1.5	1.6	1.9	52°	58°	53°
¼R2	¼RR2	1.2	0.65	0.89	1.1	1.2	1.5	1.7	1.9	2.0	2.2	2.6	43°	50°	46°
¼R3	¼RR3	1.5	0.97	1.3	1.6	1.8	2.2	2.5	2.8	3.0	3.3	3.9	52°	65°	59°
¼R3.5	¼RR3.5	1.6	1.1	1.6	1.9	2.1	2.6	3.0	3.3	3.6	3.8	4.5	43°	50°	46°
¼R5	¼RR5	2.0	1.6	2.2	2.7	3.1	3.7	4.2	4.7	5.1	5.5	6.4	52°	65°	59°
¼R6.5	¼RR6.5	2.3	2.1	2.9	3.5	4.0	4.8	5.5	6.1	6.6	7.1	8.4	45°	50°	46°
	¼FF6.5	2.3	2.1	2.9	3.5	4.0	4.8	5.5	6.1	6.6	7.1	8.4	45°	50°	46°
¼R10	¼RR10	2.9	3.2	4.5	5.4	6.1	7.4	8.4	9.3	10.2	10.9	12.9	58°	67°	61°
	¼FF10	2.9	3.2	4.5	5.4	6.1	7.4	8.4	9.3	10.2	10.9	12.9	58°	67°	61°
¾R9.5	¾RR9.5	2.6	3.1	4.2	5.1	5.8	7.0	8.0	8.9	9.7	10.4	12.2	45°	50°	46°
	¾FF9.5	2.6	3.1	4.2	5.1	5.8	7.0	8.0	8.9	9.7	10.4	12.2	45°	50°	46°
¾R15	¾RR15	3.6	4.9	6.7	8.0	9.2	11.1	12.7	14.0	15.2	16.4	19.3	64°	67°	61°
	¾FF15	3.6	4.9	6.7	8.0	9.2	11.1	12.7	14.0	15.2	16.4	19.3	64°	67°	61°
¾R22	¾RR22	4.5	7.1	9.8	11.8	13.5	16.3	18.6	21	22	24	28	87°	90°	82°
	¾FF22	4.5	7.1	9.8	11.8	13.5	16.3	18.6	21	22	24	28	87°	90°	82°
½R16	½RR16	3.5	5.2	7.1	8.6	9.8	11.8	13.5	15.0	16.3	17.5	21	48°	50°	46°
½R25	½RR25	4.6	8.1	11.1	13.4	15.3	18.5	21	23	25	27	32	64°	67°	61°
	½FF25	4.6	8.1	11.1	13.4	15.3	18.5	21	23	25	27	32	64°	67°	61°
½R32	½RR32	5.2	10.4	14.2	17.2	19.6	24	27	30	33	35	41	72°	75°	68°
½R40	½RR40	6.2	12.9	17.8	21	24	30	34	37	41	44	51	88°	91°	83°
	½FF40	6.2	12.9	17.8	21	24	30	34	37	41	44	51	88°	91°	83°
¾F2.5	¾FF2.5	4.9	9.5	13.1	15.8	18.1	22	25	28	30	32	38	48°	50°	46°
¾F4	¾FF4	6.4	15.3	21	25	29	35	40	44	48	51	61	67°	70°	63°
¾F7	¾FF7	9.5	27	37	44	51	61	70	77	84	90	106	89°	92°	84°
1F4.2	1FF4.2	6.0	16.0	22	27	30	37	42	46	50	54	64	48°	50°	46°
1F7	1FF7	8.3	27	37	44	51	61	70	77	84	90	106	67°	68°	62°
1F10	1FF10	11.9	38	52	63	72	87	99	100	120	129	151	78°	90°	94°
1F12	1FF12	11.9	46	63	76	87	104	119	132	144	154	182	89°	92°	84°

## Application Examples

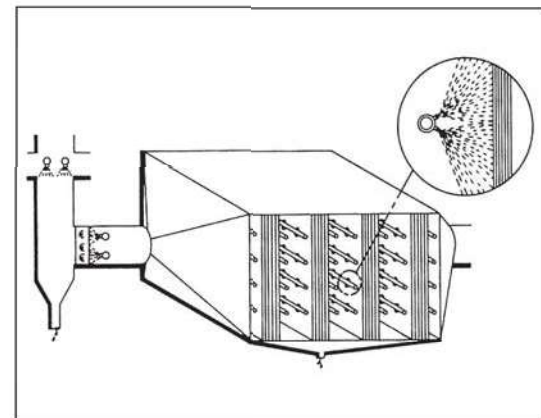
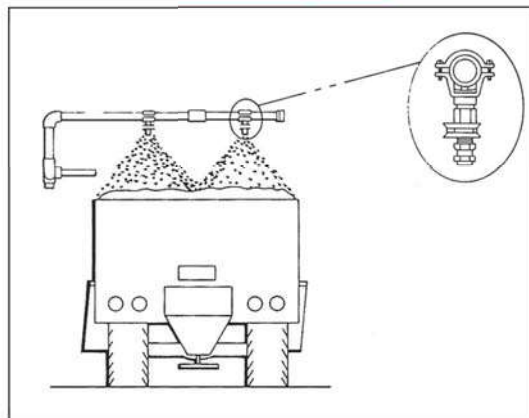



# FULL CONE NOZZLE



## R-W/RR-W F-W/FF-W TYPE

### Features

- Wide-angle solid cone-shaped spray pattern with round impact area
- Unique vane design with large flow passages provides superior control and uniform distribution.
- Removable caps and vanes for easy inspection and cleaning on most models.
- Removable vane has location marks for proper positioning after cleaning.

### Materials

-303, 304, 316 Stainless Steel, Brass, PVC / Other materials available upon request

### Applications

- Cooling, Chemical processing
- Dust control, Fire suppression/prevention
- Gas scrubbing, washing and cooling

120°



Type R  
Male Separable Type



Type FF  
Male One-piece Type



Type F-W Male

Nozzle Number		Orifice Dia (mm)	Capacity ( ℓ /min)								Spray Angle		
Conn. F	Conn. M		0.3 kg/cm <sup>2</sup>	1 kg/cm <sup>2</sup>	1.5 kg/cm <sup>2</sup>	2 kg/cm <sup>2</sup>	3 kg/cm <sup>2</sup>	4 kg/cm <sup>2</sup>	5 kg/cm <sup>2</sup>	6 kg/cm <sup>2</sup>	0.5 kg/cm <sup>2</sup>	3 kg/cm <sup>2</sup>	5 kg/cm <sup>2</sup>
1/8R2.8W	1/8RR2.8W	1.4		1.2	1.5	1.7	2.0	2.3	2.5	2.7	120°	120°	102°
1/8R4.3W	1/8RR4.3W	1.9		1.9	2.3	2.6	3.1	3.5	3.9	4.2	120°	120°	102°
1/8R5.6W	1/8RR5.6W	2.0		2.5	3.0	3.4	4.0	4.6	5.0	5.5	120°	120°	102°
1/8R8W	1/8RR8W	2.5		3.5	4.2	4.8	5.7	6.5	7.2	7.8	120°	120°	103°
1/4R10W	1/4RR10W	2.8	2.6	4.4	5.3	6.0	7.2	8.1	9.0	9.7	120°	120°	103°
1/4R12W	1/4RR12W	3.3	3.1	5.3	6.3	7.2	8.6	9.8	10.8	11.7	120°	120°	103°
1/4R14W	1/4RR14W	3.6	3.6	6.2	7.4	8.4	10.0	11.4	12.6	13.6	120°	120°	103°
3/8R20W	3/8RR20W 3/8FF20W	4.4	5.2	8.8	10.6	12.0	14.4	16.3	18.0	19.5	120°	121°	104°
3/8R24W	3/8RR24W 3/8FF24W	4.5	6.2	10.6	12.7	14.4	17.2	19.5	22	23	120°	121°	104°
3/8R27W	3/8RR27W 3/8FF27W	4.7	7.0	11.9	14.3	16.2	19.4	22	24	26	120°	121°	106°
1/2R30W	1/2RR30W 1/2FF30W	5.1	7.8	13.3	15.89	18.0	22	24	27	29	120°	121°	108°
1/2R35W	1/2RR35W 1/2FF35W	5.9	9.1	15.5	18.5	21	25	29	31	34	120°	121°	108°
1/2R40W	1/2RR40W 1/2FF40W	6.3	10.4	17.7	21	24	29	33	36	39	120°	121°	108°
1/2R45W	1/2RR45W 1/2FF45W	6.3	11.7	19.9	24	27	32	37	40	44	120°	121°	110°
1/2R50W	1/2RR50W 1/2FF50W	6.7	13.0	22	26	30	36	41	45	49	120°	121°	112°
3/4F6W	3/4FF6W	9.8	18.3	31	37	42	50	57	63	68	120°	121°	112°
1F11W	1FF11W	13.1	33	57	68	77	92	105	116	125	120°	124°	117°
1 1/4F16W		15.5	49	83	99	112	134	152	168	182	121°	124°	119°
1 1/2F24W		18.2	73	124	148	169	200	230	250	275	124°	125°	119°
2F47W		25.0	143	245	290	330	395	445	495	540	124°	125°	119°
2 1/2F70W		31.8	215	360	430	490	590	670	740	800	125°	125°	119°
3F95W		34.9	290	490	590	670	800	910	1000	1080	125°	125°	119°
4F188W		50.8	570	970	1160	1320	1580	1790	1980	2140	125°	125°	119°

## Dimensions and Weights

Nozzle Number	A Max (mm)	B Max (mm)	Weight Max (kg)	Nozzle Number	A Max (mm)	B Max (mm)	Weight Max (kg)
1/8R	31.0	14.3 육각	0.03	3/8FF	40.5	φ 27.0	0.10
1/8R	37.5	17.5 육각	0.04	1FF	53.5	φ 33.3	0.20
1/8R	46.0	20.6 육각	0.07	3/4F	55.5	φ 31.8	0.21
1/8R	57.2	25.4 육각	0.17				
1/4RR	32.5	14.3 육각	0.02	1F	70.0	φ 38.1	0.36
1/4RR	40.0	17.5 육각	0.04	1 1/4F	87.5	φ 52.4	0.48
3/8RR	47.0	20.6 육각	0.07	1 1/2F	102	φ 58.7	0.68
1/2RR	56.5	25.4 육각	0.17	2F	138	φ 76.2	1.6
1/2FF	23.0	φ 13.5	0.01	2 1/2F	163.2	φ 87.3	2.2
	30.5	φ 16.7	0.03	3F	187	φ 104.8	2.7
	34.9	φ 20.6	0.04	4F	251	φ 138.1	8.2

# FULL CONE NOZZLE

FULL CONE NOZZLE



## F, FH Type

### Features

- One piece design
- Large droplet sizes
- Even atomization and distribution

### Materials

- Brass, 303, 304, 316 Stainless Steel and PVC / Other materials available upon request

### Applications

- High volume surface spraying / Scrubbers
- Gas cooling / Chemical processing / Fire suppression

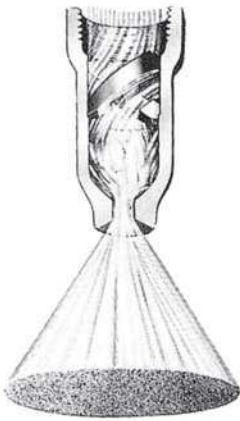

Type F  
Female Type



Type FH  
Flange Conn.

Nozzle Number		Orifice Dia (mm)	Capacity ( ℓ /min)											Spray Angle		
Conn. F	Conn. Flange		0.5 kg/cm <sup>2</sup>	0.7 kg/cm <sup>2</sup>	1 kg/cm <sup>2</sup>	1.5 kg/cm <sup>2</sup>	2 kg/cm <sup>2</sup>	3 kg/cm <sup>2</sup>	4 kg/cm <sup>2</sup>	5 kg/cm <sup>2</sup>	6 kg/cm <sup>2</sup>	7 kg/cm <sup>2</sup>	10 kg/cm <sup>2</sup>	0.5 kg/cm <sup>2</sup>	1.5 kg/cm <sup>2</sup>	4 kg/cm <sup>2</sup>
1¼F6		7.4	23	27	31	38	43	52	60	66	72	77	91	48°	50°	46°
1¼F610		9.6	38	45	52	63	72	87	99	110	120	129	151	64°	67°	61°
1¼F12		10.7	46	53	63	76	87	104	119	132	144	154	182	66°	70°	63°
1¼F14		12.3	53	62	73	88	101	122	139	154	168	180	210	77°	80°	73°
1¼F20		15.1	76	89	105	126	144	174	199	220	240	255	300	90°	93°	85°
1½F10		9.5	38	45	52	63	72	87	99	110	120	129	151	48°	50°	46°
1½F16		12.7	61	71	84	101	116	139	159	176	192	205	240	72°	74°	67°
1½F20		14.3	76	89	105	126	144	174	199	220	240	255	300	74°	76°	69°
1½F30		18.3	114	134	157	190	215	260	300	330	360	385	455	91°	94°	86°
2F17		12.7	65	76	89	107	123	148	169	187	205	220	255	49°	50°	46°
2F30		17.3	114	134	157	190	215	260	300	330	360	385	455	72°	74°	67°
2F35		19.2	133	156	184	220	250	305	345	385	420	450	530	75°	77°	70°
2F40		21.0	153	178	210	250	290	350	395	440	480	510	610	78°	80°	73°
2F50		23.8	191	220	260	315	360	435	495	550	600	640	760	83°	85°	78°
2F60		28.6	230	265	315	380	435	520	600	660	720	770	910	98°	100°	91°
2½F25		15.1	95	111	131	158	181	215	250	275	300	320	380	49°	50°	46°
2½F50		22.2	191	220	260	315	360	435	495	550	600	640	760	72°	74°	67°
2½F60		24.6	230	265	315	380	435	520	600	660	720	770	910	76°	78°	71°
2½F70		28.6	265	310	365	440	510	610	700	770	840	900	1060	79°	82°	75°
2½F80		28.6	305	355	420	510	580	700	800	880	960	1030	1210	86°	88°	80°
2½F90		31.8	345	400	470	570	650	780	890	990	1080	1160	1360	95°	97°	88°
3F42		19.1	160	187	220	265	305	365	415	460	500	540	640	49°	50°	46°
3F80		27.8	305	355	420	510	580	700	800	880	960	1030	1210	81°	84°	76°
3F90		30.2	345	400	470	570	650	780	890	990	1080	1160	1360	86°	89°	81°
3F100		32.5	380	445	520	630	720	870	990	1100	1200	1290	1510	92°	95°	87°
3F120		34.9	455	530	630	760	870	1040	1190	1320	1440	1540	1820	102°	105°	93°
4F160	4FH160	42.9	610	710	840	1010	1160	1390	1590	1760	1920	2060	2420	87°	90°	73°
4F180	4FH180	47.2	690	800	940	1140	1300	1570	1790	1980	2160	2310	2730	92°	95°	87°
4F200	4FH200	50.8	760	890	1050	1260	1440	1740	1990	2200	2400	2570	3030	97°	100°	91°
4F210	4FH210	54.8	800	930	1100	1330	1520	1830	2090	2310	2510	2700	3180	102°	105°	95°
5F250	5FH250	47.6	950	1110	1310	1580	1810	2180	2480	2750	2990	3210	3790	89°	91°	83°
5F280	5FH280	52.8	1070	1250	1470	1770	2020	2440	2780	3080	3350	3600	4240	93°	96°	88°
5F320	5FH320	68.3	1220	1420	1680	2020	2310	2790	3180	3520	3830	4110	4850	97°	100°	91°
5F330	5FH330	72.2	1260	1470	1730	2090	2380	2870	3280	3630	3950	4240	5000	102°	105°	95°
6F350	6FH350	61.1	1330	1560	1840	2210	2530	3050	3480	3850	4190	4500	5300	87°	90°	82°
6F400	6FH400	69.1	1530	1780	2100	2530	2890	3480	3980	4400	4790	5150	6050	92°	95°	87°
6F450	6FH450	77.0	1720	2000	2360	2840	3250	3920	4470	4960	5400	5800	6800	97°	100°	91°
6F480	6FH480	81.8	1830	2140	2520	3030	3470	4180	4770	5300	5750	6150	7250	102°	105°	95°
8F500	8FH500	69.9	1910	2230	2620	3160	3610	4350	4970	5500	6000	6400	7550	78°	80°	73°
8F600	8FH600	80.2	2290	2670	3150	3790	4330	5200	5950	6600	7200	7700	9100	86°	88°	80°
8F700	8FH700	91.3	2670	3120	3670	4420	5050	6100	6950	7700	8400	9000	10600	92°	95°	87°
8F800	8FH800	102	3050	3560	4200	5050	5750	6950	7950	8800	9600	10300	12100	102°	105°	95°
8F900	8FH900	124	3430	4010	4720	5700	6500	7850	8950	9900	10800	11600	13600	106°	110°	100°
10FH800		85.1	3050	3560	4200	5050	5750	6950	7950	8800	9600	10300	12100	78°	80°	73°
10FH1000		101	3810	4450	5250	6300	7200	8700	9950	11000	12000	12900	15100	86°	89°	81°
10FH1200		122	4580	5350	6300	7600	8650	10400	11900	13200	14400	15400	18200	97°	100°	91°
10FH1300		135	4960	5800	6800	8200	9400	11300	12900	14300	15600	16700	19700	103°	106°	96°

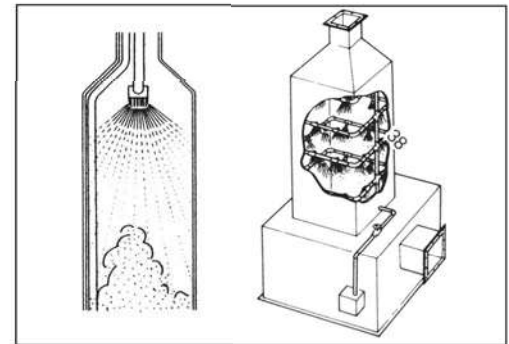
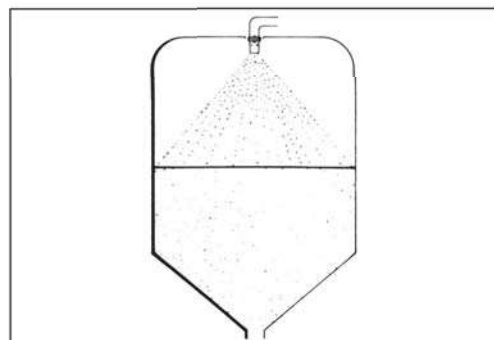



# FULL CONE NOZZLE(WALL MOUNTED)



## RD,RRD,FD TYPE

### Features

- Solid narrow angle cone-shaped spray pattern and spray angles of 15° and 30°
- Significantly higher impact per unit area than wider angle nozzles at the same flow rate.
- Designed to be disassembled, in the form of the R, RR has two forms.

### Materials

- Brass, 303, 304, 316 Stainless Steel and PVC / Other materials available on request

### Applications

- Spraying into chemical reaction vessels
- Spraying into storage tanks and bins
- Spraying into steam and gas lines

Nozzle Number		Conn. NPT or PT	Orifice Dia (mm)	Max. Free Passage Dia (mm)	Capacity ( ℓ /min)										Spray Angle		
Inlet Conn. F	Inlet Conn. M				0.5 kg/cm <sup>2</sup>	1 kg/cm <sup>2</sup>	2 kg/cm <sup>2</sup>	3 kg/cm <sup>2</sup>	4 kg/cm <sup>2</sup>	5 kg/cm <sup>2</sup>	6 kg/cm <sup>2</sup>	7 kg/cm <sup>2</sup>	10 kg/cm <sup>2</sup>	0.5 kg/cm <sup>2</sup>	1.5 kg/cm <sup>2</sup>	5 kg/cm <sup>2</sup>	
1/8RD1	1/8RRD1	1/8"	0.89	0.64		0.45	0.61	0.74	0.84	0.93	1.0	1.1	1.3		58°	53°	
1/8RD2	1/8RRD2	1/8"	1.2	1.0	0.65	0.89	1.2	1.5	1.7	1.9	2.0	2.2	2.6	43°	50°	46°	
1/8RD3	1/8RRD3	1/8"	1.5	1.0	0.97	1.3	1.8	2.2	2.5	2.8	3.0	3.3	3.9	52°	65°	59°	
1/8RD3.5	1/8RRD3.5	1/8"	1.6	1.3	1.1	1.6	2.1	2.6	3.0	3.3	3.6	3.8	4.5	43°	50°	46°	
1/8RD5	1/8RRD5	1/8"	2.0	1.3	1.6	2.2	3.1	3.7	4.2	4.7	5.1	5.5	6.4	52°	65°	59°	
1/4RD6.5	1/4RRD6.5	1/4"	2.3	1.6	2.1	2.9	4.0	4.8	5.5	6.1	6.6	7.1	8.4	45°	50°	46°	
1/4RD10	1/4RRD10	1/4"	2.9	1.6	3.2	4.5	6.1	7.4	8.4	9.3	10.2	10.9	12.9	58°	67°	61°	
3/8RD9.5	3/8RRD9.5	3/8"	2.6	2.4	3.1	4.2	5.8	7.0	8.0	8.9	9.7	10.4	12.2	45°	50°	46°	
3/8RD15	3/8RRD15	3/8"	3.6	2.4	4.9	6.7	9.2	11.1	12.7	14.0	15.2	16.4	19.3	64°	67°	61°	
1/2RD16	1/2RRD16	1/2"	3.5	3.2	5.2	7.1	9.8	11.8	13.5	15.0	16.3	17.5	21	48°	50°	46°	
1/2RD25	1/2RRD25	1/2"	4.6	3.2	8.1	11.1	15.3	18.5	21	23	25	27	32	64°	67°	61°	
3/4FD2.5		3/4"	4.9	4.4	9.5	13.1	18.1	22	25	28	30	32	38	48°	50°	46°	
3/4FD4		3/4"	6.4	4.4	15.3	21	29	35	40	44	48	51	61	67°	70°	63°	
1FD4.2		1"	6.0	5.6	16.0	22	30	37	42	46	50	54	64	48°	50°	46°	
1FD7		1"	8.3	5.6	27	37	51	61	70	77	84	90	106	67°	68°	62°	
1 1/4FD10		1 1/4"	9.6	6.4	38	52	72	87	99	110	120	129	151	64°	67°	61°	
1 1/4FD12		1 1/4"	10.7	6.4	46	63	87	104	119	132	144	154	182	66°	70°	63°	
1 1/2FD16		1 1/2"	12.7	8.7	61	84	116	139	159	176	192	205	240	72°	74°	67°	
1 1/2FD20		1 1/2"	14.3	8.7	76	105	144	174	199	220	240	255	300	74°	76°	69°	
2FD30		2"	17.3	11.1	114	157	215	260	300	330	360	385	455	72°	74°	67°	
2FD35		2"	19.2	11.1	133	184	250	305	345	385	420	450	530	75°	77°	70°	
2FD40		2"	21.0	11.1	153	210	290	350	395	440	480	510	610	78°	80°	73°	
2FD60		2"	25.4	11.1	230	315	435	520	600	660	720	770	910	98°	100°	91°	
2 1/2FD25		2 1/2"	15.0	14.3	95	131	181	215	250	275	300	320	380	49°	50°	46°	
2 1/2FD50		2 1/2"	22.2	14.3	191	260	360	435	495	550	600	640	760	72°	74°	67°	
2 1/2FD60		2 1/2"	24.6	14.3	230	315	435	520	600	660	720	770	910	76°	78°	71°	
2 1/2FD70		2 1/2"	27.0	14.3	265	365	510	610	700	770	840	900	1060	79°	82°	75°	
3FD42		3"	19.1	17.5	160	220	305	365	415	460	500	540	640	49°	50°	46°	
3FD80		3"	27.8	17.5	305	420	580	700	800	880	960	1030	1210	81°	84°	76°	
3FD90		3"	30.2	17.5	345	470	650	780	890	990	1080	1160	1360	86°	89°	81°	
3FD100		3"	32.5	17.5	380	520	720	870	990	1100	1200	1290	1510	92°	95°	87°	

★ Maximum Free Passage Diameter is the maximum diameter as listed of foreign matter that can pass through the nozzle without clogging.

## Dimensions and Weights

Nozzle Number	A max (mm)	B max (mm)	Weight Max (kg)
1/8RD	35	14.3옥각	0.03
1/8RRD	37	14.3옥각	0.03
1/4RD	41	17.5옥각	0.04
1/4RRD	43	17.5옥각	0.04
3/8RD	46	20.6옥각	0.07
3/8RRD	47	20.6옥각	0.07
1/2RD	56	25.4옥각	0.14
1/2RRD	55	25.4옥각	0.13
3/4FD	54	φ 31.8	0.17
1FD	68	φ 38.1	0.40
1 1/4FD	86	φ 47.6	0.68
1 1/2FD	103	φ 57.2	1.1
2FD30			
2FD35	129	φ 69.39	2.0
2FD40			
2FD60	122	φ 69.9	2.0
2 1/2FD	159	φ 82.6	3.2
3FD	186	φ 101.6	5.8



Type RD Female Inlet Separate Type



Type RRD Male Inlet Separate Type



Type FD Female Inlet One piece Type

All Wall mounted is Male connection, same size as in Inlet connection.

### Ordering info

Ex) Stainless steel,  
Male - 1/4RRD-SS10  
Brass,  
Female - 1/4RD-10

# FULL CONE NOZZLE

## TF TYPE

### Features

- High energy efficiency
- One-piece/no internal parts
- Clog-resistant performance
- High discharge velocity

### Materials

-Brass, 303, 304, 316 Stainless Steel and PVC / Other materials available on request

### Applications

- Washing and Rinsing, Gas Cooling, Chemical Processing
- Cooling, Washing/Rinsing, Fire protection/Suppression, Gas scrubbing

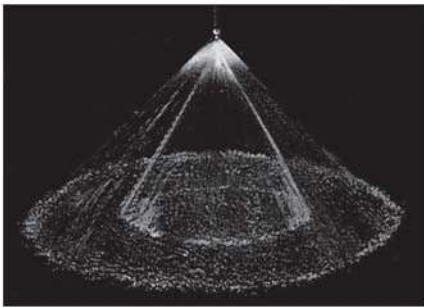

FULL CONE 60°



FULL CONE 90°



90° 120° Metal

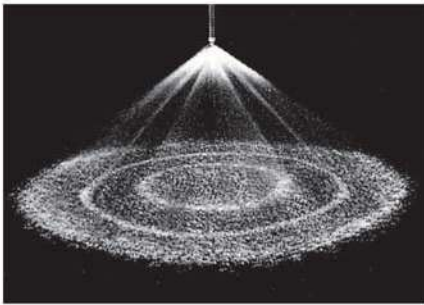

FULL CONE 120°

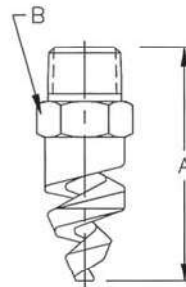

60°, 90°, 120°

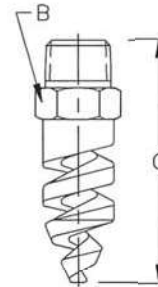

150°, 170°

Male Pipe Size	Nozzle Number	Available Spray Angles					Orifice Dia. (mm)	Capacity (ℓ/min)								SIZE		
		60°	90°	120°	150°	170°		0.5	0.7	1 kg/cm <sup>2</sup>	2 kg/cm <sup>2</sup>	3 kg/cm <sup>2</sup>	5 kg/cm <sup>2</sup>	10 kg/cm <sup>2</sup>	20 kg/cm <sup>2</sup>	A	B	C
1/8	TF6	60°	90°	120°			2.38	2.26	2.67	3.19	4.5	5.5	7.1	10.1	14.3	42.9	14.3	
	TF8	60°	90°	120°			3.18	4.19	4.96	5.93	8.4	10.3	13.2	18.7	26.5			
1/4	TF6	60°	90°	120°			2.38	2.26	2.67	3.19	4.5	5.5	7.1	10.1	14.3	47.6	14.3	
	TF8	60°	90°	120°			3.18	4.19	4.96	5.93	8.4	10.3	13.2	18.7	26.5			
	TF10	60°	90°	120°			3.97	6.45	7.63	9.12	12.9	15.8	20.4	28.8	40.8			
3/8	TF6	60°					2.38	2.26	2.67	3.19	4.5	5.5	7.1	10.1	14.3	47.6	17.5	80.5
	TF8	60°					3.18	4.19	4.96	5.93	8.4	10.3	13.2	18.7	26.5			
	TF10	60°					3.97	6.45	7.63	9.12	12.9	15.8	20.4	28.8	40.8			
	TF12	60°	90°	120°	150°	170°	4.76	9.67	11.4	13.7	19.3	23.7	30.6	43.2	61.1			
	TF14	60°	90°	120°	150°	170°	5.56	13.1	15.4	18.5	26.1	32.0	41.3	58.4	62.6			
	TF16	60°	90°	120°	150°	170°	6.35	17.1	20.2	24.2	34.2	41.6	54.0	76.4	108			
1/2	TF24	60°	90°	120°	150°	170°	9.53	38.8	46.0	54.9	77.7	95.1	123	174	246	63.5	22.2	77.7
	TF28	60°	90°	120°	150°	170°	11.1	53.2	62.9	75.2	106	130	168	238	336			
3/4	TF32	60°	90°	120°	150°	170°	12.7	67.7	80.1	95.7	135	166	214	303	428	69.9	28.6	88.9
1	TF40	60°	90°	120°	150°	170°	15.9	108	128	153	216	264	341	483	683	92.1	34.9	111
	TF48	60°	90°	120°	150°	170°	19.1	153	181	216	306	375	484	685	958			
1 1/2	TF56	60°	90°	120°	150°	170°	22.2	208	246	294	416	509	657	930	1320	11.1	50.8	137
	TF64	60°	90°	120°	150°	170°	25.4	272	322	385	545	657	861	1220	1720			
	TF72	60°	90°	120°	150°	170°	28.6	309	366	438	619	758	978	1380	1960			
2	TF88		90°	120°	150°	170°	34.9	451	534	638	902	1110	1430	2020	2850	143	63.5	175
	TF96		90°	120°	150°	170°	38.1	570	674	805	1140	1400	1800	2550	3600			
3	TF112		90°	120°			44.5	825	976	1170	1650	2020	2610	3690	5220	21.9	88.9	
	TF128		90°	120°			50.8	1090	1290	1550	2190	2080	3460	4891	6920			
4	TF160		90°	120°			63.5	1690	2000	2300	3380	4140	5350	7570	10700	257	114	

# ANGLE형 FULL CONE NOZZLE

FULL CONE NOZZLE



## RA, RRA TYPE

### Features

- Solid cone-shape spray pattern with round impact area
- Injection at a 90-degree angle from the entrance to the angled
- Resolution attached to the cap and van

### Materials

- Brass, 303, 304, 316 Stainless Steel and PVC / Other materials available on request



Angle Type RA fulljet  
Female with Standard Cap



Angle Type  
Male with Wide  
Angle Cap  
RRA-W Male, RA-W  
fulljet also available

Nozzle Number		Orifice Dia (mm)	Capacity ( ℓ /min)										Spray Angle		
Female	Male		0.3 kg/cm <sup>2</sup>	0.5 kg/cm <sup>2</sup>	1 kg/cm <sup>2</sup>	1.5 kg/cm <sup>2</sup>	2 kg/cm <sup>2</sup>	3 kg/cm <sup>2</sup>	4 kg/cm <sup>2</sup>	5 kg/cm <sup>2</sup>	6 kg/cm <sup>2</sup>	7 kg/cm <sup>2</sup>	0.5 kg/cm <sup>2</sup>	1.5 kg/cm <sup>2</sup>	5 kg/cm <sup>2</sup>
¼RA2	¼RRA2	1.2	0.51	0.65	0.89	1.1	1.2	1.5	1.7	1.9	2.0	2.2	43°	50°	46°
¼RA3	¼RRA3	1.5	0.77	0.97	1.3	1.6	1.8	2.2	2.5	2.8	3.0	3.3	52°	65°	59°
¼RA3.5	¼RRA3.5	1.6	0.90	1.1	1.6	1.9	2.1	2.6	3.0	3.3	3.6	3.8	43°	50°	46°
¼RA5	¼RRA5	2.0	1.3	1.6	2.2	2.7	3.1	3.7	4.2	4.7	5.1	5.5	52°	65°	59°
¼RA6.5	¼RRA6.5	2.3	1.7	2.1	2.9	3.5	4.0	4.8	5.5	6.1	6.6	7.1	45°	50°	46°
¼RA10	¼RRA10	2.9	2.6	3.2	4.5	5.4	6.1	7.4	8.4	9.3	10.2	10.9	58°	67°	61°
⅜RA9.5	⅜RRA9.5	2.7	2.4	3.1	4.2	5.1	5.8	7.0	8.0	8.9	9.7	10.4	45°	50°	46°
⅜RA15	⅜RRA15	3.7	3.8	4.9	6.7	8.0	9.2	11.1	12.7	14.0	15.2	16.4	64°	67°	61°
⅜RA20	⅜RRA20	4.0	5.1	6.5	8.9	10.7	12.2	14.8	16.9	18.7	20	22	76°	80°	73°
⅜RA22	⅜RRA22	4.7	5.6	7.1	9.8	11.8	13.5	16.3	18.6	21	22	24	87°	90°	82°
½RA16	½RRA16	3.5	4.1	5.2	7.1	8.6	9.8	11.8	13.5	15.0	16.3	17.5	48°	50°	46°
½RA25	½RRA25	4.6	6.4	8.1	11.1	13.4	15.3	18.5	21	23	25	27	64°	67°	61°
½RA32	½RRA32	5.2	8.2	10.4	14.2	17.2	19.6	24	27	30	33	35	72°	75°	68°
½RA40	½RRA40	6.7	10.2	12.9	17.8	21	24	30	34	37	41	44	88°	91°	83°
½RA50	½RRA50	6.7	12.8	16.2	22	27	31	37	42	47	51	55	91°	94°	86°

## ANGLE TYPE WIDE ANGLE FULL CONE NOZZLE

### RA-W, RRA-W TYPE(120°)

Nozzle Number		Orifice Dia (mm)	Capacity ( ℓ /min)										Spray Angle		
Female	Male		0.3 kg/cm <sup>2</sup>	0.5 kg/cm <sup>2</sup>	1 kg/cm <sup>2</sup>	1.5 kg/cm <sup>2</sup>	2 kg/cm <sup>2</sup>	3 kg/cm <sup>2</sup>	4 kg/cm <sup>2</sup>	5 kg/cm <sup>2</sup>	6 kg/cm <sup>2</sup>	7 kg/cm <sup>2</sup>	1 kg/cm <sup>2</sup>	3 kg/cm <sup>2</sup>	5 kg/cm <sup>2</sup>
¼RA4.3W	¼RA4.3W	1.9			1.9	2.3	2.6	3.1	3.5	3.9	4.2	4.5	120°	120°	102°
¼RA8W	¼RA8W	2.5		2.6	3.5	4.2	4.8	5.7	6.5	7.2	7.8	8.3	120°	120°	103°
¼RA14W	¼RA14W	3.6	3.6	4.6	6.2	7.4	8.4	10.0	11.4	12.6	13.6	14.6	120°	120°	103°
⅜RA20W	⅜RA20W	4.4	5.2	6.5	8.8	10.6	12.0	14.4	16.3	18.0	19.5	21	120°	121°	104°
½RA35W	½RA35W	5.9	9.1	11.4	15.5	18.5	21	25	29	31	34	36	120°	121°	108°
½RA50W	½RA50W	6.7	13.0	16.3	22	26	30	36	41	45	49	52	120°	120°	108°

## Dimensions and Weights

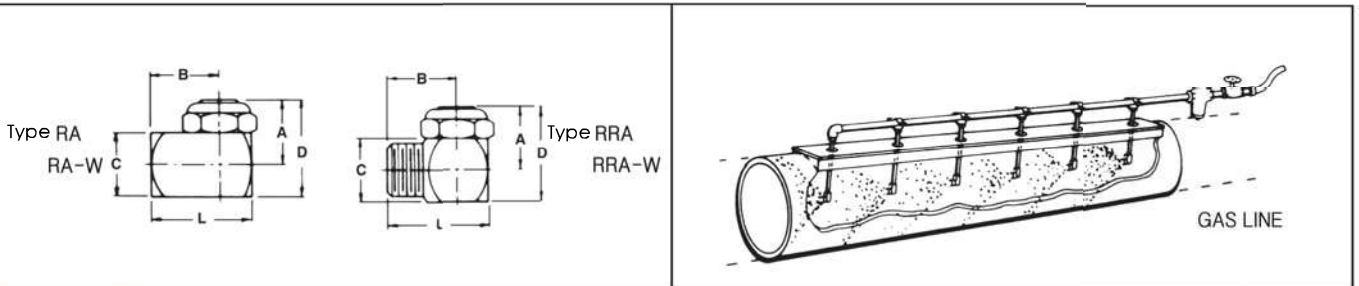

Nozzle Number	Dimensions					Weight Max(Kg)	Nozzle Number	Dimensions					Weight Max(Kg)
	A Max (mm)	B Max (mm)	C Max (mm)	D Max (mm)	L Max (mm)			A Max (mm)	B Max (mm)	C Max (mm)	D Max (mm)	L Max (mm)	
¼RA	14	16	14.3사각	21	23	0.04	¼RRA	14	17	14.3	21	24	0.04
¼RA	19	20	17.4사각	28	29	0.05	¼RRA	19	21	17.4	28	29	0.06
⅜RA	20	22	20.6사각	30	33	0.09	⅜RRA	20	23	20.6	30	33	0.09
½RA50	30	27	25.4사각	43	40	0.17	½RRA50	30	29	25.4	43	41	0.17
¼RA-W	16	16	14.3사각	23	23	0.04	¼RRA-W	16	17	14.3	23	24	0.04
¼RA-W	22	20	17.4사각	30	29	0.05	¼RRA-W	22	21	17.4	30	29	0.06
⅜RA-W	23	22	20.6사각	34	33	0.09	⅜RRA-W	23	23	20.6	34	33	0.09
½RA50W	32	27	25.4사각	45	40	0.18	½RRA50W	32	29	25.4	45	41	0.18

# FULL CONE NOZZLE : ANGLE TYPE(VANELESS FULL CONE)

## Features

- Vaneless' full-cone design
- Large maximum free passage
- Easy disassembly/assembly and cleaning

## Construction

- Vaneless Cap and Body

## Materials

- Brass, 303, 304, 316 Stainless Steel / Other materials available on request

## Applications

- Gas washing, Foam break, Cooling
- Cooling of primary metals and other materials

## Dimensions and Weights

Nozzle Number	Nozzle Type	Dimensions(mm)				Weight (kg)
		A	B	C	D	
1/4"	RRNM	28.5	15.9	21.0	8.0	53
1/4"	RRNF	28.5	15.9	21.0	8.0	66
3/8"	RRNM	35.0	19.0	26.0	9.5	89
3/8"	RRNF	35.0	19.0	26.0	9.5	100
1/2"	RRNM	44.5	25.4	35.5	12.7	184
1/2"	RRNF	44.5	25.4	35.5	12.7	200
3/4"	RRNM	57.0	31.8	43.0	16.0	350
3/4"	RRNF	57.0	31.8	43.0	16.0	370
1"	RRNM	76.0	38.1	50.5	19.0	695
1"	RRNF	76.0	38.1	50.0	19.0	715



Male Type



Female Type

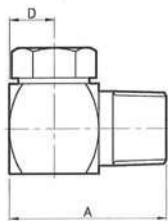

RBIM (MALE)

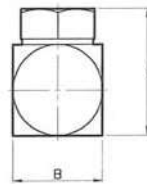
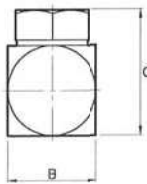

RBIF (FEMALE)

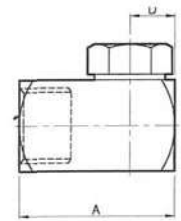

Nozzle Number		BEST THREAD SIZE						Capacity ( ℓ /min)										Spray Angle		
Female	Male	1/8	1/4	3/8	1/2	3/4	1	0.35	7	1	1.5	2	3	4	6	7	8	7	2	6
RRF6	RRM6	●	●					0.88	1.25	1.50	1.88	2.18	2.65	2.87	3.41	3.54	3.76	40	47	40
RRF8	RRM8	●	●					1.30	1.86	2.28	2.84	3.23	4.00	4.55	5.38	5.72	5.97	44	56	53
RRF11	RRM11	●	●					1.63	2.32	2.87	3.62	4.05	4.87	5.36	6.30	6.74	7.06	52	64	58
RRF12	RRM12	●	●					2.09	2.79	3.41	4.09	4.55	5.30	5.91	7.02	7.58	8.01	62	70	58
RRF16	RRM16		●					2.50	3.58	4.41	5.30	6.14	7.27	8.00	9.51	10.04	10.61	57	60	55
RRF20	RRM20		●					3.11	4.46	5.46	6.50	7.54	9.06	10.00	11.92	12.63	13.43	62	73	58
RRF22	RRM22		●					3.58	5.11	6.24	7.51	8.32	9.78	10.91	13.23	14.24	14.95	70	80	62
RRF12	RRM12			●				2.00	2.79	3.32	4.19	4.73	5.83	6.60	7.79	8.17	8.65	36	45	39
RRF16	RRM16			●				2.50	3.58	4.41	5.30	6.14	7.27	8.00	9.51	10.04	10.61	57	60	55
RRF20	RRM20			●				3.11	4.46	5.46	6.50	7.54	9.06	10.00	11.92	12.63	13.43	61	73	58
RRF22	RRM22			●				3.58	5.11	6.24	7.51	8.32	9.78	10.91	13.23	14.24	14.95	70	80	62
RRF27	RRM27			●				4.23	6.04	7.42	9.01	10.10	12.32	13.64	16.06	17.47	18.08	70	80	62
RRF32	RRM32			●				5.81	7.25	8.88	10.81	12.32	14.44	15.96	19.29	20.40	22.12	70	80	62
RRF27	RRM27				●			4.23	6.04	7.42	9.01	10.10	12.32	13.64	16.06	17.47	18.08	44	53	51
RRF32	RRM32				●			5.81	7.25	8.88	10.81	12.32	14.44	15.96	19.29	20.40	22.12	60	70	61
RRF42	RRM42				●			6.74	9.67	11.82	14.44	15.96	19.29	21.41	24.95	27.37	28.48	70	76	64
RRF49	RRM49				●			8.17	11.62	14.24	16.36	18.69	23.13	25.05	29.29	32.52	33.94	79	86	72
RRF63	RRM63				●			10.20	14.44	17.07	20.50	23.84	28.89	32.22	38.48	41.31	43.94	80	86	70
RRF47	RRM47					●		7.48	10.61	13.03	14.95	17.78	21.11	26.63	28.48	30.20	31.71	43	57	42
RRF63	RRM63					●		10.20	14.44	17.07	20.50	23.84	28.89	32.22	38.48	41.31	43.94	60	69	53
RRF77	RRM77					●		12.32	17.68	20.50	23.94	29.09	34.95	38.68	45.65	49.29	52.02	70	73	60
RRF89	RRM89					●		13.94	20.00	23.74	29.39	33.63	40.00	44.54	52.92	56.26	59.29	82	85	67
RRF102	RRM102					●		14.85	20.91	27.37	33.73	38.68	46.26	50.00	60.10	64.54	67.87	85	97	74
RRF73	RRM73						●	11.92	16.26	20.00	22.62	27.78	34.24	38.68	45.65	50.00	52.02	35	41	44
RRF105	RRM105						●	16.26	23.23	27.78	33.73	39.79	48.18	52.32	62.42	67.37	71.51	51	57	49
RRF123	RRM123						●	19.49	28.38	34.64	42.32	46.56	57.77	63.63	75.95	80.40	85.55	66	73	57
RRF140	RRM140						●	22.73	32.02	38.18	45.25	53.23	62.12	68.18	80.80	85.95	90.90	75	81	52
RRF162	RRM162						●	25.55	36.26	44.64	53.03	61.41	72.22	79.08	95.14	101.00	108.07	74	86	63
RRF193	RRM193						●	28.79	41.81	50.10	60.70	73.23	87.57	99.08	119.18	128.27	135.34	82	100	80

# HOLLOW CONE NOZZLE

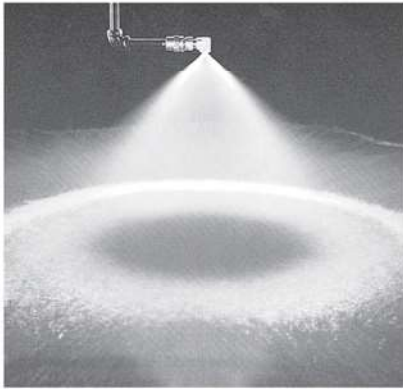

## HX,HCX Type

### Features

- Circular Hollow Spray Pattern with Uniform Distribution
- Swirl Type Nozzle with Clog Resistance Body
- Body and Cap of the Nozzle are Designed for Disassembly
- 200~5,000 $\mu$  Particle Diameter
- High Durability

### Materials

- Brass, 303, 304, 316 Stainless Steel / Other materials available on request

### Applications

- Cleaning Various Kinds of Industrial Products
- Gas Collection, Dust Collection
- Handling Before and After the Painting
- Cleaning Gas, Cooling Gas, Fire Prevention

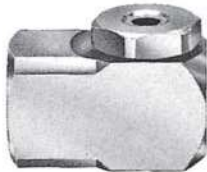

Slope-bottom design  
HX Female Type



Slope-bottom design  
HCX Male Type

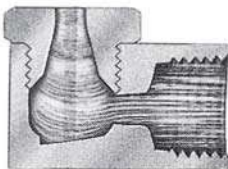

Slope-bottom design  
for water vortex

## 60°~90°

Nozzle Number			Orifice Dia. (mm)	Capacity (ℓ/min)										Spray Angle		
HX Female	HCX Male	Capacity Size		0.5 kg/cm <sup>2</sup>	1 kg/cm <sup>2</sup>	1.5 kg/cm <sup>2</sup>	2 kg/cm <sup>2</sup>	3 kg/cm <sup>2</sup>	4 kg/cm <sup>2</sup>	5 kg/cm <sup>2</sup>	6 kg/cm <sup>2</sup>	7 kg/cm <sup>2</sup>	0.5 kg/cm <sup>2</sup>	1.5 kg/cm <sup>2</sup>	5 kg/cm <sup>2</sup>	
1/4HX	1/4HCX	1	1.4	0.32	0.45	0.55	0.64	0.78	0.90	1.0	1.1	1.2	36°	64°	76°	
		2	2.0	0.64	0.90	1.1	1.3	1.6	1.8	2.0	2.2	2.4	52°	61°	69°	
		3	2.4	0.96	1.4	1.7	1.9	2.3	2.7	3.0	3.3	3.6	52°	64°	77°	
		5	3.3	1.6	2.3	2.8	3.2	3.9	4.5	5.1	5.5	6.0	56°	67°	76°	
		8	3.9	2.6	3.6	4.4	5.1	6.3	7.2	8.1	8.9	9.6	56°	65°	70°	
		10	4.4	3.2	4.5	5.5	6.4	7.8	9.0	10.1	11.1	12.0	55°	65°	72°	
1/2HX	1/2HCX	1	1.4	0.45	0.55	0.64	0.78	0.90	1.0	1.1	1.2	53°	67°	71°		
		2	2.2	0.64	0.90	1.1	1.3	1.6	1.8	2.0	2.2	2.4	48°	62°	71°	
		3	2.4	0.96	1.4	1.7	1.9	2.3	2.7	3.0	3.3	3.6	51°	65°	78°	
		5	3.7	1.6	2.3	2.8	3.2	3.9	4.5	5.1	5.5	6.0	63°	73°	79°	
		8	4.0	2.6	3.6	4.4	5.1	6.3	7.2	8.1	8.9	9.6	61°	69°	73°	
		10	4.5	3.2	4.5	5.5	6.4	7.8	9.0	10.1	11.1	12.0	63°	70°	74°	
3/8HX	3/8HCX	5	3.3	1.6	2.3	2.8	3.2	3.9	4.5	5.1	5.5	6.0	64°	73°	79°	
		8	4.2	2.6	3.6	4.4	5.1	6.3	7.2	8.1	8.9	9.6	62°	70°	74°	
		10	4.5	3.2	4.5	5.5	6.4	7.8	9.0	10.1	11.1	12.0	64°	72°	75°	
		15	5.4	4.8	6.8	8.3	9.6	11.7	13.6	15.2	16.6	17.9	64°	72°	74°	
		20	6.4	6.4	9.0	11.1	12.8	15.7	18.1	20	22	24	63°	70°	74°	
		25	7.4	8.0	11.3	13.8	16.0	19.6	23	25	28	30	63°	70°	74°	
1/2HX	1/2HCX	30	7.9	9.6	13.5	16.6	19.2	23	27	30	33	36	63°	70°	74°	
		25	6.4	8.0	11.3	13.8	16.0	19.6	23	25	28	30	63°	66°	71°	
		30	7.5	9.6	13.5	16.6	19.2	23	27	30	33	36	67°	71°	75°	
		40	9.1	12.8	18.1	22	26	31	36	40	44	48	72°	76°	78°	
		50	11.1	16.0	23	28	32	39	45	51	55	60	74°	79°	82°	
		60	13.1	19.2	27	33	38	47	54	61	66	72	77°	82°	86°	
3/4HX	3/4HCX	40	7.9	12.8	18.1	22	26	31	36	40	44	48	70°	73°	74°	
		50	9.5	16.0	23	28	32	39	45	51	55	60	72°	75°	77°	
		60	11.1	19.2	27	33	38	47	54	61	66	72	74°	76°	79°	
		70	12.7	22	32	39	45	55	63	71	78	84	76°	79°	83°	
		80	14.3	26	36	44	51	63	72	81	89	96	78°	82°	84°	
		90	14.7	29	41	50	57	70	81	91	100	108	81°	84°	84°	
		100	15.9	32	45	55	64	78	90	101	111	120	83°	86°	86°	
		110	17.1	35	50	61	70	86	99	111	122	132	85°	88°	88°	
		120	18.3	38	54	66	77	94	109	121	133	144	87°	90°	90°	

## Dimensions and Weights

Type HX Female	Weight Max (kg)	A Max (mm)	B Max (mm)	C Max (mm)	D Max (mm)	L Max (mm)	Type HX Male	Weight Max (kg)	A Max (mm)	B Max (mm)	C Max (mm)	D Max (mm)	L Max (mm)
1/4HX	0.04	17.5	16.0	11.5	19.0	25.5	1/4HCX	0.04	22.5	16.0	11.5	19.0	30.5
1/2HX	0.08	22.5	19.0	13.5	23.0	32.0	1/2HCX	0.07	25.5	19.0	13.5	23.0	35.0
3/8HX	0.12	26.5	22.5	16.0	27.0	37.5	3/8HCX	0.11	28.5	22.5	16.0	27.0	40.0
1/2HX	0.25	35.0	28.5	20.0	34.5	49.5	1/2HCX	0.20	35.0	28.5	20.0	34.5	49.5
3/4HX	0.31	40.0	32.0	22.5	38.5	55.5	3/4HCX	0.30	41.5	32.0	22.5	38.5	57.5



# WIDE HOLLOW CONE SPRAY NOZZLE



## HX-W, HCX-W TYPE

### Features

- Circular Hollow Spray Pattern with Uniform Distribution
- Super Wide Angle Spray
- Easy to Change Cap
- High Durability
- Inclination is on the Bottom of Nozzle

### Materials

- Brass, 303, 304, 316 Stainless Steel /
- Other materials available on request



Slope-bottom design  
HCX-W Male Type



Slope-bottom design  
HX-W Female Type

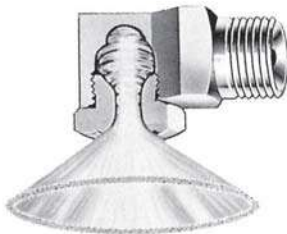

Slope-bottom design  
reduces the drilling effect  
of the fluid vortex  
in the fluid chamber.

120°

Nozzle Number		Capacity Size	Orifice Dia. (mm)	Body Inlet Dia. (mm)	Capacity (ℓ/min)										Spray Angle
HX Female	HCX Male				0.3 kg/cm <sup>2</sup>	0.5 kg/cm <sup>2</sup>	1 kg/cm <sup>2</sup>	1.5 kg/cm <sup>2</sup>	2 kg/cm <sup>2</sup>	3 kg/cm <sup>2</sup>	4 kg/cm <sup>2</sup>	5 kg/cm <sup>2</sup>	6 kg/cm <sup>2</sup>	0.7 kg/cm <sup>2</sup>	
1/4HX	1/4HCX	0.5W	1.1	0.91			0.23	0.28	0.32	0.39	0.45	0.51	0.55	112°	
		1W	1.7	1.4			0.45	0.55	0.64	0.78	0.90	1.0	1.1	114°	
		3W	2.7	2.1		0.80	1.1	1.4	1.6	2.0	2.3	2.5	2.8	114°	
		1-3W	2.7	2.4		0.96	1.4	1.7	1.9	2.3	2.7	3.0	3.3	114°	
		5W	3.3	2.4		1.1	1.5	1.9	2.2	2.7	3.1	3.4	3.8	116°	
		10W	4.5	2.1		1.3	1.9	2.3	2.6	3.2	3.7	4.1	4.5	130°	
		1-5W	3.3	3.0		1.6	2.3	2.8	3.2	3.9	4.5	5.1	5.5	116°	
		10W	4.5	3.0	1.6	2.1	2.9	3.6	4.1	5.1	5.9	6.6	7.2	126°	
		1-10W	4.5	3.8	2.2	2.9	4.1	5.0	5.7	7.0	8.1	9.1	10.0	124°	
1/2HX	1/2HCX	1W	1.7	1.4			0.45	0.55	0.64	0.78	0.90	1.0	1.1	110°	
		5W	3.3	1.4			0.77	0.94	1.1	1.3	1.5	1.7	1.9	100°	
		10W	4.5	1.4			0.95	1.2	1.3	1.6	1.9	2.1	2.3	112°	
		15W	5.4	1.4			1.1	1.3	1.5	1.9	2.2	2.4	2.7	105°	
		1-5W	3.3	2.1		1.1	1.5	1.9	2.2	2.7	3.1	3.4	3.8	118°	
		1-10W	4.5	2.1		1.3	1.9	2.3	2.6	3.2	3.7	4.1	4.5	138°	
		2-5W	3.3	3.6		1.6	2.3	2.8	3.2	3.9	4.5	5.1	5.5	114°	
		2-10W	4.5	3.6	1.6	2.1	2.9	3.6	4.1	5.1	5.9	6.6	7.2	130°	
		1-15W	5.4	3.6	1.9	2.5	3.5	4.3	4.9	6.0	7.0	7.8	8.5	130°	
		3-10W	4.5	4.1	2.2	2.9	4.1	5.0	5.7	7.0	8.1	9.1	10.0	129°	
		4-10W	4.5	4.7	2.5	3.2	4.5	5.5	6.4	7.8	9.0	10.1	11.1	120°	
		2-15W	5.4	4.1	2.7	3.5	5.0	6.1	7.0	8.6	9.9	11.1	12.2	129°	
		3-15W	5.4	4.7	3.0	3.8	5.4	6.6	7.7	9.4	10.9	12.1	13.3	120°	
4-15W	5.4	5.8	3.7	4.8	6.8	8.3	9.6	11.7	13.6	15.2	16.6	101°			
3/4HX	3/4HCX	10W	4.5	3.5	1.6	2.1	2.9	3.6	4.1	5.1	5.9	6.6	7.2	130°	
		15W	5.4	3.5	1.9	2.5	3.5	4.3	4.9	6.0	7.0	7.8	8.5	138°	
		1-10W	4.5	4.5	2.2	2.9	4.1	5.0	5.7	7.0	8.1	9.1	10.0	122°	
		2-10W	4.5	5.0	2.5	3.2	4.5	5.5	6.4	7.8	9.0	10.1	11.1	116°	
		1-15W	5.4	4.5	2.7	3.5	5.0	6.1	7.0	8.6	9.9	11.1	12.2	133°	
		2-15W	5.4	5.0	3.0	3.8	5.4	6.6	7.7	9.4	10.9	12.1	13.3	126°	
		25W	7.4	4.5	3.2	4.1	5.9	7.2	8.3	10.2	11.8	13.1	14.4	122°	
		20W	5.9	5.0	3.5	4.5	6.3	7.7	8.9	11.0	12.7	14.2	15.5	118°	
		3-15W	5.4	6.1	3.7	4.8	6.8	8.3	9.6	11.7	13.6	15.2	16.6	116°	
		1-20W	5.9	6.1	4.2	5.4	7.7	9.4	10.9	13.3	15.4	17.2	18.8	113°	
		2-20W	5.9	7.1	4.9	6.4	9.0	11.1	12.8	15.7	18.1	20	22	106°	
30W	7.9	6.1	5.4	7.0	9.9	12.2	14.0	17.2	19.9	22	24	116°			
1-25W	7.4	7.4	6.2	8.0	11.3	13.8	16.0	19.6	23	25	28	105°			
1-30W	7.9	7.4	6.9	8.9	12.6	15.5	17.9	22	25	28	31	105°			
1/2HX	1/2HCX	50W	11.1	9.5	12.4	16.0	23	28	32	39	45	51	55	110°	
3/4HX	3/4HCX	80W	14.3	12.7	19.8	26	36	44	51	63	72	81	89	115°	

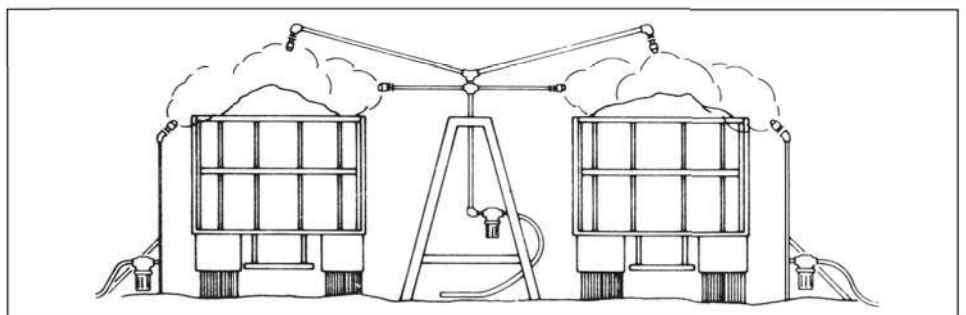

# HOLLOW CONE NOZZLE

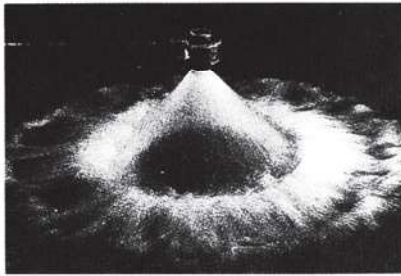

## HX, HCX TYPE

### Features

- Large capacity, hollow spray pattern
- Durability with chemical resistance and temperature
- One-piece angle type

### Materials

- 1" or more casting products
- Cast brass
- Cast Stainless steel
- Other materials available upon request

### Application

- Gas washing, dust control
- Fire suppression/prevention



Type HX (Female)



Type HDX (Male)

Hollow spray pattern

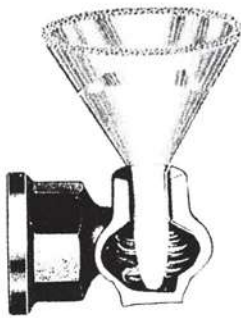

Type HCX  
Slope-bottom design reduces the drilling effect of the fluid vortex in the fluid chamber.

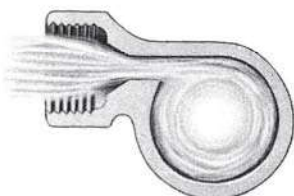

For free flow of liquid and foreign the inlet and the diameter of the orifice passage is large.

Nozzle Number		Orifice Dia. (mm)	Capacity (ℓ/min)										Spray Angle		
HX Female	HCX, HDX Male		0.5 kg/cm <sup>2</sup>	0.7 kg/cm <sup>2</sup>	1 kg/cm <sup>2</sup>	1.5 kg/cm <sup>2</sup>	2 kg/cm <sup>2</sup>	3 kg/cm <sup>2</sup>	4 kg/cm <sup>2</sup>	5 kg/cm <sup>2</sup>	6 kg/cm <sup>2</sup>	7 kg/cm <sup>2</sup>	0.5 kg/cm <sup>2</sup>	1.5 kg/cm <sup>2</sup>	4 kg/cm <sup>2</sup>
	½HCX3	7.5	11.4	13.5	16.2	19.8	23	28	32	36	40	43	60°	63°	65°
	½HCX4	9.5	15.3	18.1	22	26	31	37	43	48	53	57	68°	71°	73°
	½HCX5	11.5	19.1	23	27	33	38	47	54	60	66	71	74°	77°	80°
	½HCX7	13.5	27	32	38	46	53	66	76	85	93	100	77°	80°	83°
	½HDX3	7.9	11.4	13.5	16.2	19.8	23	28	32	36	40	43	62°	65°	67°
	½HDX4	9.9	15.3	18.1	22	26	31	37	43	48	53	57	68°	71°	73°
	½HDX5	11.9	19.1	23	27	33	38	47	54	60	66	71	74°	77°	80°
	½HDX7	13.9	27	32	38	46	53	66	76	85	93	100	77°	80°	83°
	¾HCX5	10.1	19.1	23	27	33	38	47	54	60	66	71	59°	61°	63°
	¾HCX6	11.5	23	27	32	40	46	56	65	73	79	86	62°	64°	66°
	¾HCX7	12.7	27	32	38	46	53	66	76	85	93	100	70°	71°	72°
	¾HCX10	16.3	38	45	54	66	76	94	108	121	132	143	73°	75°	77°
	¾HDX4	9.1	15.3	18.1	22	26	31	37	43	48	53	57	65°	66°	67°
	¾HDX5	10.7	19.1	23	27	33	38	47	54	60	66	71	68°	69°	70°
	¾HDX6	12.3	23	27	32	40	46	56	65	73	79	86	70°	73°	77°
	¾HDX7	13.9	27	32	38	46	53	66	76	85	93	100	72°	75°	80°
	¾HDX10	16.7	38	45	54	66	76	94	108	121	132	143	77°	80°	84°
1HX7	1HCX7	11.4	27	32	38	46	53	66	76	85	93	100	64°	65°	66°
1HX8	1HCX8	12.8	31	36	43	53	61	75	86	97	106	114	65°	66°	67°
1HX9	1HCX9	14.2	34	41	49	59	69	84	97	109	119	129	66°	67°	69°
1HX10	1HCX10	15.6	38	45	54	66	76	94	108	121	132	143	67°	69°	71°
1HX12	1HCX12	17.1	46	54	65	79	92	112	130	145	159	172	70°	73°	75°
1HX15	1HCX15	20.7	57	68	81	99	115	140	162	181	199	215	76°	79°	81°
1¼HX10	1¼HCX10	14.3	38	45	54	66	76	94	108	121	132	143	65°	67°	67°
1¼HX12	1¼HCX12	16.3	46	54	65	79	92	112	130	145	159	172	68°	70°	71°
1¼HX14	1¼HCX14	18.3	53	63	76	93	107	131	151	169	185	200	71°	73°	75°
1¼HX16	1¼HCX16	20.2	61	72	86	106	122	150	173	193	210	230	74°	75°	77°
1¼HX20	1¼HCX20	24.2	76	90	108	132	153	187	215	240	265	285	76°	77°	79°
1¼HX16	1¼HCX16	17.4	61	72	86	106	122	150	173	193	210	230	64°	67°	69°
1¼HX20	1¼HCX20	21.8	76	90	108	132	153	187	215	240	265	285	69°	72°	74°
1¼HX25	1¼HCX25	25.8	95	113	135	165	191	235	270	300	330	355	72°	74°	76°
1¼HX30	1¼HCX30	28.6	114	135	162	198	230	280	325	360	395	430	74°	76°	78°
2HX30	2HCX30	23.6	114	135	162	198	230	280	325	360	395	430	66°	67°	70°
2HX35	2HCX35	27.0	134	158	189	230	265	325	380	420	465	500	68°	70°	73°
2HX40	2HCX40	30.2	153	181	215	265	305	375	430	485	530	570	70°	72°	75°
2HX45	2HCX45	33.1	172	205	240	295	345	420	485	540	600	640	72°	74°	78°
2HX50	2HCX50	36.0	191	225	270	330	380	470	540	600	660	710	74°	77°	82°
2HX60	2HCX60	39.8	230	270	325	395	460	560	650	730	790	860	77°	79°	84°
2½HX60	2½HCX60	36.1	230	270	325	395	460	560	650	730	790	860	67°	68°	71°
2½HX70	2½HCX70	40.4	265	315	375	460	530	660	760	850	930	1000	69°	71°	74°
2½HX80	2½HCX80	44.1	305	360	430	530	610	750	860	970	1060	1140	71°	73°	77°
2½HX90	2½HCX90	47.6	345	405	485	590	690	840	970	1090	1190	1290	73°	75°	80°
2½HX100	2½HCX100	50.8	380	450	540	660	760	940	1080	1210	1320	1430	77°	79°	83°

## Dimensions and Weights

Nozzle Number	Weight Max (kg)	A Max (mm)	B Max (mm)	C Max (mm)	D Max (mm)	L Max (mm)	Nozzle Number	Weight Max (kg)	A Max (mm)	B Max (mm)	C Max (mm)	D Max (mm)	L Max (mm)
½HX	0.13	33	33	5.5	19	48	1HX, HCX	0.31	45	47	9	27	67
½HDX	0.14	44	33	6.5	19	59	1¼HX, HCX	0.57	53	56	11.5	32	78
¾HX	0.20	38	42	7.5	23	58	1½HX, HCX	0.79	62	73	14.5	42	94
¾HDX	0.21	51	42	8	24	69	2HX, HCX	1.4	75	94	18.5	54	115
							2½HX, HCX	1.9	89	115	24	69	141

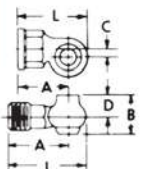

# FOG JET NOZZLE



## CL-7 TYPE

### Features

-The CL-7 series FogJet nozzle produces a shower-like full cone spray pattern of very fine droplets.

### Construction

-Body and 7 removable FullJet spray caps

### Materials

-Brass, 303 Stainless steel

### Application

-Gas washing, humidification, tank cooling



CL-7 Female Type

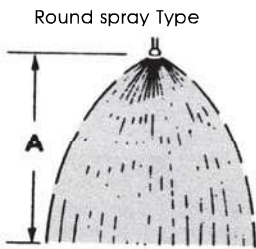

Round spray Type

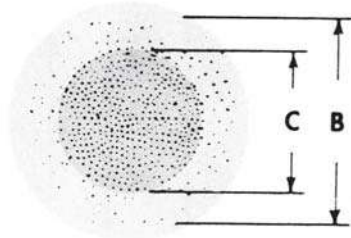

"C" area density distribution within the range of about 65% of the total area "B" represents the area, has a full range of spray distribution. Approximately 35% of the total distribution "C" is the only area, the density distribution of the form of the distribution closer to the end will be lower.

"Ordering info :  
Ex)  
Stainless steel : 3/4 CL7-SS1  
Brass : 3/4 CL7-1

Nozzle Number	Spray distance			Capacity ( ℓ /min)						
	A m	B m	C m	1 kg/cm <sup>2</sup>	2 kg/cm <sup>2</sup>	3 kg/cm <sup>2</sup>	5 kg/cm <sup>2</sup>	6 kg/cm <sup>2</sup>	8 kg/cm <sup>2</sup>	10 kg/cm <sup>2</sup>
¾-CL-7, 1	1	1.5	1	3.1	4.3	5.2	6.5	7.1	8.1	9.0
	1.5	2	1.3							
	2.5	2.3	1.5							
¾-CL-7, 1.5	1	2.5	1.7	4.7	6.5	7.8	9.3	10.6	12.1	13.6
	1.5	2.7	2.0							
	2.5	3.0	2.3							
¾-CL-7, 3	1	2.6	1.7	9.3	12.9	15.5	19.5	21	24	27
	1.5	3	2							
	2.5	3.3	2.1							
¾-CL-7, 5	1	3	1.9	15.6	21	26	33	36	41	45
	1.5	3.3	2.1							
	2.5	3.6	2.4							
1-CL-7, 10	1	2.2	1.5	31	43	52	65	71	81	90
	1.5	3	1.9							
	2.5	3.6	2.4							
1-CL-7, 12.5	1	3.7	3.0	39	53	65	82	89	102	112
	1.5	4.0	3.4							
	2.5	4.3	3.7							
1-CL-7, 25 1½-CL-7, 25	1	4	2.7	78	107	129	164	178	205	225
	1.5	4.9	3.2							
	2.5	5.2	3.3							
1-CL-7, 30 1½-CL-7, 30	1	4	2.7	93	129	155	193	215	245	270
	1.5	4.9	3.2							
	2.5	5.2	3.3							
1-CL-7, 32 1½-CL-7, 32	1	4	2.7	100	137	166	210	225	260	285
	1.5	4.9	3.2							
	2.5	5.2	3.3							
1-CL-7, 40 1½-CL-7, 40	1	4	2.7	125	171	205	260	285	325	360
	1.5	4.9	3.2							
	2.5	5.2	3.3							
1½-CL-7, 45	1	4.2	2.9	140	193	230	295	320	365	405
	1.5	5.0	3.3							
	2.5	5.3	3.6							
1½-CL-7, 50	1	4.4	3.2	156	215	260	325	355	405	450
	1.5	5.2	3.6							
	2.5	5.5	4							

Nozzle Number	Inlet Pipe NPT or PT	H Max (mm)	D Max (mm)	Weight (kg)
¾-CL-7,1 ¾-CL-7,3	¾"	45	53	0.34
¾-CL-7,5	¾"	46	54	0.34
1-CL-7,10	1"	56	69	0.68
1-CL-7, 25~ 1-CL-7, 40	1"	84	104	1.6
1½-CL-7, 25~ 1½-CL-7, 45	1½"	76	102	1.7
1½-CL-7, 50	1½"	81	108	1.6

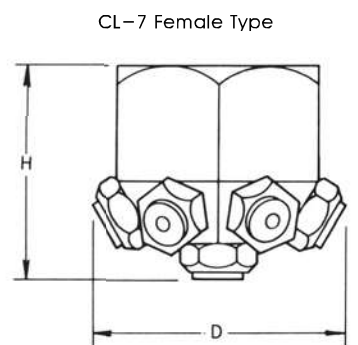

# Flomax Air Auto mizing



## FM TYPE

### Features

- FloMax nozzles use a patented three-stage atomization principle to produce a highly focused air stream that shears the liquid with minimal air.
- Compressed air use and energy consumption are low.

### Materials

- 316,316L Stainless Steel, Hastelloy C&G
- Other materials available on request.

### Application

- Cooling prior to baghouse, ESP, heat exchanger, kilns
- Cooling towers, Induct cooling
- NOx control, SO2 removal

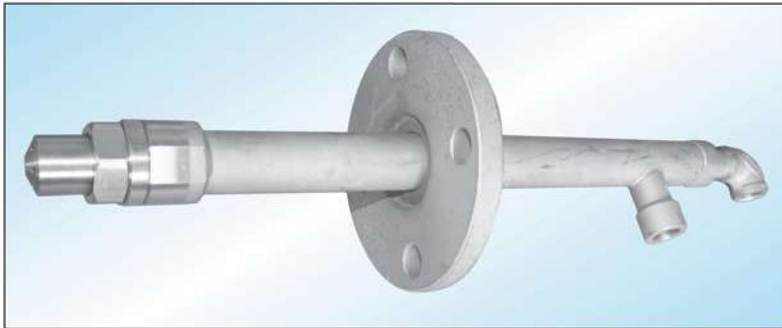

AA-SA001

Nozzle Number	Air (bar)	Liquid (bar)	Capacity (ℓ/min)
AA-SA001	2	0.97	1.88
		1.18	3.78
		1.57	7.57
		1.79	9.46
	3	2.02	1.87
		2.27	3.79
		2.79	7.57
		3.05	9.46
	4	3.02	1.89
		3.35	3.79
		3.99	7.57
		4.31	9.45
5.5	3.99	1.89	
	4.36	3.79	
	5.21	7.57	
	5.48	9.45	



AA-SA005

Nozzle Number	Air (bar)	Liquid (bar)	Capacity (ℓ/min)
AA-SA005	2	2.31	7.57
		3.03	15.13
		3.96	22.72
		3.37	7.57
	4	4.13	15.13
		5.12	22.72
		3.91	7.57
		4.73	15.13
	4.8	5.67	22.72
		4.54	7.57
		5.39	15.13
		6.28	22.72



AA-SA010

Nozzle Number	Air (bar)	Liquid (bar)	Capacity (ℓ/min)
AA-SA010	2.8	2.63	15.1
		3.24	30.4
		4.01	45.4
	4.2	3.86	15.2
		4.48	30.3
		5.31	45.5
	4.8	4.48	15.2
		5.17	30.3
		6.01	45.5
	5.5	5.11	15.1
		5.79	30.3
		6.59	45.4



AA-SA250

Nozzle Number	Air (bar)	Liquid (bar)	Capacity (ℓ/min)
AA-SA250	2.1	2.56	56.7
		2.83	68.2
		3.16	79.5
	2.8	3.22	56.7
		3.9	68.2
		3.82	79.5
	4.2	4.38	56.7
		4.75	68.2
		5.11	79.5



# TANK CLEANING SPRAY NOZZLE

## Applications

- TCIP SYSTEM, Various process tank, Mixer
- pray dryer, power tower, dryer tower
- Fructose, fermentation, yeast tank
- Storage tank, chemical tank

## Features

- The flow of the cleaning fluid causes the body of the cleaning head to rotate providing a swirling impact.
- Water, detergent, chemical available



TZ-02

## TYPE TZ-02

### SPECIFICATIONS

#### Materials

Bronze, AISI 316L, PTFE, PVDF, Carbon

#### Weight

15 kgs (33 lbs) portable model  
16 kgs (35.3 lbs) fixed model

#### Lubricant

Self-lubricating with the cleaning fluid

#### Working pressure

2-12 Bar (30-174 psi)

#### Recommended pressure

5-10 Bar(72-145 psi)

#### Max. working temperature

95°C (203°F)

#### Max. throw length

22-36m (72-118 ft.)

#### Installation

Fixed or portable

#### Standard thread

2" NPT or 2½" ASA for portable installation

#### Flange

φ 165 · PC125 · 4 × φ 19mm(0.75") holes



SJ-RTZ

## SJ-RTZ-650

### Features

- The flow of the cleaning fluid causes the body of the cleaning head to rotate providing a swirling impact.
- The flow of the cleaning fluid makes the nozzles perform a geared rotation around the vertical and horizontal axis.
- Maximum throw length is 25m

### Working pressure

-5kg/cm<sup>2</sup> -25kg/cm<sup>2</sup>

### Materials

-Body-316L Stainless steel , tungsten, viton

Nozzle Number	Capacity ( ℓ /min)								Nozzle(Ø)
	2	3	4	5	7	10	15	20	
RTZ22-316LSS	100	120	140	155	185	220	260	300	6.0
RTZ32-316LSS	145	180	200	230	275	325	400	460	8.0
RTZ40-316LSS	180	220	250	280	330	400	490	580	10.0



CL-9 Female Type



CL-19 Male Type

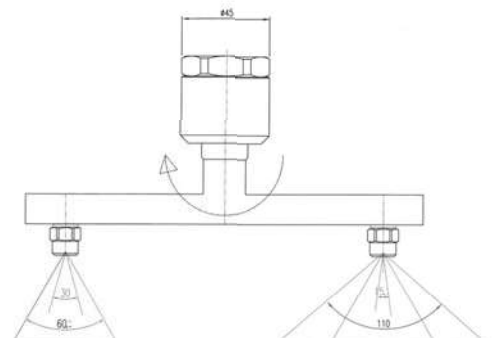

For self-cleaning

# TANK CLEANING SPRAY NOZZLE

## Features

- The flow of the cleaning fluid causes the body of the cleaning head to rotate
- Effective internal scrubbing of small tanks and drums

## Working pressure

- 3 kg/cm<sup>2</sup> -7 kg/cm<sup>2</sup>

## Applications

- Drum, brewery, distillery

## Materials

- Body - 316L Stainless steel
- other materials available upon request.

### SJ-RTW-PERFORMANCE DATA



Nozzle Number	Capacity (ℓ/min)								PipeConn (PT.NPT)	A	B	C	D
	1	2	3	4	5	7	10	12		(mm)	(mm)	(mm)	(mm)
RTW10-316LSS	25	35	40	45	50	60	71	76	1/2".3/4"	134	59	75	56
RTW18-316LSS	40	58	70	80	89	106	126	139	1/2".3/4"	-	-	-	-
RTW31-316LSS	60	85	104	120	134	158	189	207	3/4".1"	-	-	-	-
RTW45-316LSS	100	140	171	198	221	261	310	340	3/4".1"	134	59	75	56

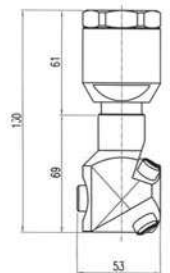

### SJ-RTR-PERFORMANCE DATA



Nozzle Number	Capacity (ℓ/min)								PipeConn (PT.NPT)	A	B	C	D
	1	2	3	4	5	7	10	12		(mm)	(mm)	(mm)	(mm)
RTR18-316LSS	40	58	70	80	89	106	126	139	1/2"	110	53.5	56.5	34
RTR31-316LSS	60	85	104	120	134	158	189	207	3/4"	120	53	67	45
RTR45-316LSS	100	140	171	198	221	261	310	340	3/4".1"	120	53	67	45
RTR60-316LSS	173	245	300	346	387	460	550	600	1-1/4"	150	70	80	85

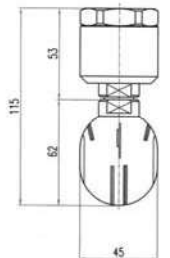

### SJ-RTR-PERFORMANCE DATA



Nozzle Number	Capacity (ℓ/min)								PipeConn (PT.NPT)	A	B	C	D
	1	2	3	4	5	7	10	12		(mm)	(mm)	(mm)	(mm)
RTM7-316LSS	16	23	28	32	36	43	50	55	3/8".1/2"	86.5	44	42.5	25
RTM10-316LSS	25	35	40	45	50	60	71	78	3/8".1/2"	-	-	-	-
RTM12-316LSS	31	43	53	61	68	80	96	105	1/2"	86.5	44	42.5	25

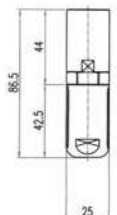

#### TYPE OF COVERAGE

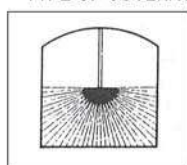

180°

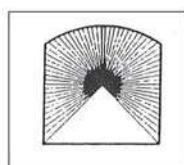

270°

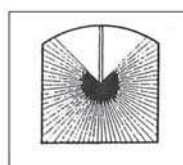

270°

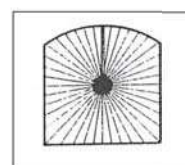

360°

# Accessories

## BJ SERIES

## BALL JOINT

## ADAPTER



(BJ + Spiral Combination)



(BJ + Veejet Combination)

### Dimensions

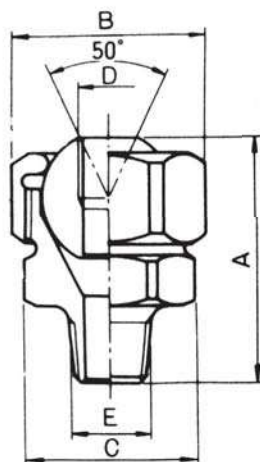

### BJ Type



#### Features

- 3 pieces construction ( BODY, BALL, Retaining Cap)
- Accessories for aligning spray directions.
- Adjustable ball joints allow custom alignment of spray nozzles without expensive piping changes
- Rapid installation and replacement of spray tips without the use of tools

#### Materials

- Brass, 303, 304, 316 Stainless Steel

#### Application

- Aligning for spray directions

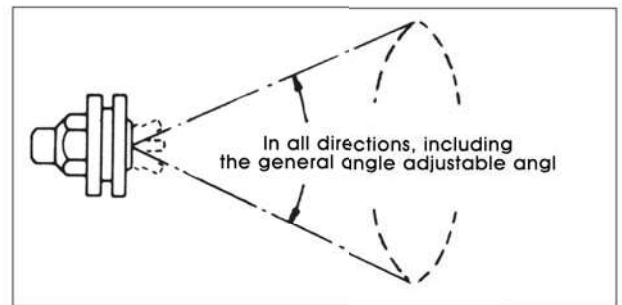

### Dimensions and Weights

Nozzle Number	Dimension					weight (kg)
	A <sub>mm</sub>	B <sub>mm</sub>	C <sub>mm</sub>	D <sub>mm</sub>	E <sub>mm</sub>	
1/8BJ	37	HE×29	HE×26	PT1/8	PT1/8	0.15
1/8×1/4BJ	40	HE×35	HE×32	PT1/8	PT1/4	0.15
1/4BJ	40	HE×35	HE×32	PT1/4	PT1/4	0.3
1/4×3/8BJ	45	HE×35	HE×32	PT1/4	PT3/8	0.3
3/8BJ	45	HE×41	HE×35	PT3/8	PT3/8	0.5
3/8×1/2BJ	48	HE×41	HE×41	PT3/8	PT1/2	0.5
1/2BJ	50	HE×50	HE×41	PT1/2	PT1/2	1.0
1/2×3/4BJ	58	HE×55	HE×50	PT1/2	PT3/4	1.0
3/4BJ	60	HE×55	HE×50	PT3/4	PT3/4	1.5
3/4×1 BJ	62	HE×55	HE×55	PT3/4	PT1	1.5



# 노즐접속용 악세사리



## CLIP-ON NOZZLE

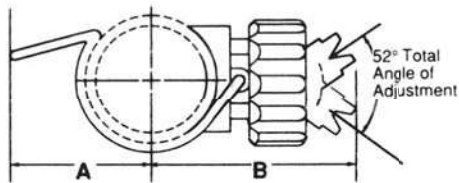
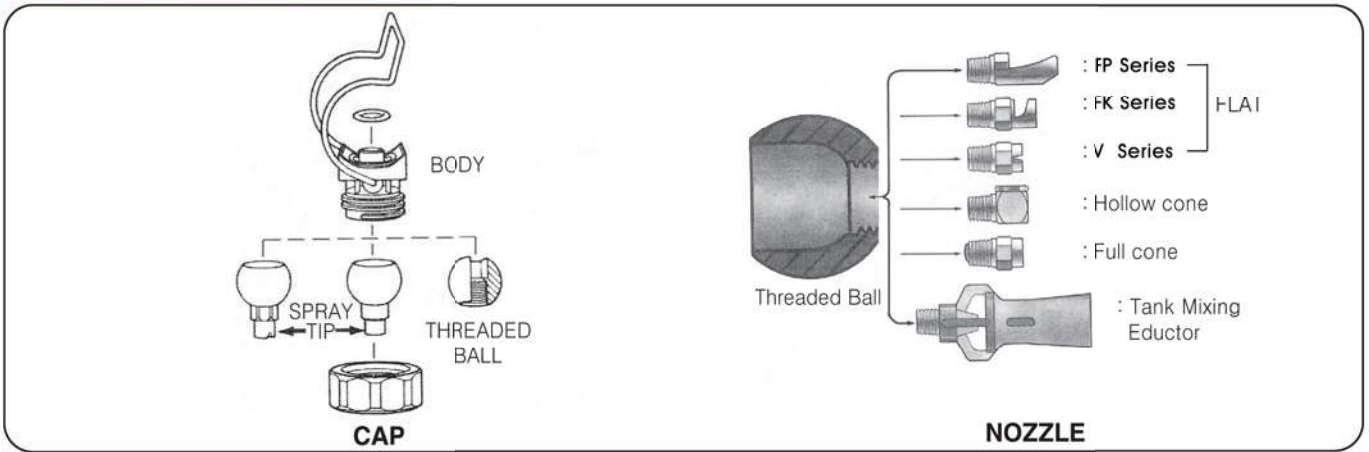

Pipe size	Dimension "A"	Dimension "B"
1"	1-3/4" (45mm)	2-7/8" (73mm)
1-1/4"	2" (51mm)	3" (77mm)
1-1/2"	2-1/8" (54mm)	3-1/8" (80mm)
2"	2-3/8" (61mm)	3-1/2" (89mm)

Spray angle at 3kg/cm <sup>2</sup>	Nozzle Number	Orifice Dia (mm)	Capacity (ℓ/min)													Spray angle			
			0.3 kg/cm <sup>2</sup>	1 kg/cm <sup>2</sup>	2 kg/cm <sup>2</sup>	3 kg/cm <sup>2</sup>	4 kg/cm <sup>2</sup>	5 kg/cm <sup>2</sup>	6 kg/cm <sup>2</sup>	7 kg/cm <sup>2</sup>	10 kg/cm <sup>2</sup>	15 kg/cm <sup>2</sup>	20 kg/cm <sup>2</sup>	30 kg/cm <sup>2</sup>	35 kg/cm <sup>2</sup>	1.5 kg/cm <sup>2</sup>	3 kg/cm <sup>2</sup>	5 kg/cm <sup>2</sup>	14 kg/cm <sup>2</sup>
110°	11060	4.8	7.4	13.5	19.2	23	27	30	33	36	43	53	61	74	80	107°	110°	117°	124°
80°	8010	2.0	1.2	2.3	3.2	3.9	4.5	5.0	5.5	6.0	7.1	8.8	10.1	12.4	13.4	75°	80°	83°	87°
	8040	4.0	4.9	9.0	12.8	15.6	18.1	20	22	24	29	35	40	50	53	76°	80°	85°	85°
	8050	4.4	6.2	11.3	16.10	19.5	23	25	28	30	36	44	51	62	67	78°	80°	85°	85°
	8060	4.8	7.4	13.5	19.2	23	27	30	33	36	43	53	61	74	80	78°	80°	86°	91°
	8070	5.2	8.6	15.8	22	27	32	35	39	42	50	61	71	87	94	78°	80°	89°	92°
	80100	6.4	12.3	23	32	39	45	50	55	60	71	88	101	124	134	75°	80°	83°	86°
65°	6520	2.8	2.5	4.5	6.4	7.8	9.0	10.1	11.1	11.9	14.3	17.5	20	25	27	61°	65°	72°	73°
	6530	3.6	3.7	6.8	9.6	11.7	13.5	15.1	16.6	17.9	21	26	30	37	40	62°	65°	72°	73°
	6540	4.0	4.9	9.0	12.8	15.6	18.1	20	22	24	29	35	40	50	53	63°	65°	72°	73°
	6550	4.4	6.2	11.3	16.0	19.5	23	25	28	30	36	44	51	62	67	63°	65°	73°	72°
	6560	4.8	7.4	13.5	19.2	23	27	30	33	36	43	53	61	74	80	63°	65°	73°	72°
	6570	5.2	8.6	15.8	22	27	32	35	39	42	50	61	71	87	94	63°	65°	74°	72°
65100	6.4	12.3	23	32	39	45	50	55	60	71	88	101	124	134	58°	65°	69°	70°	
50°	5040	4.0	4.9	9.0	12.8	15.6	18.1	20	22	24	29	35	40	50	53	43°	50°	53°	54°
	5050	4.4	6.2	11.3	16.0	19.5	23	25	28	30	36	44	51	62	67	43°	50°	53°	54°
	5060	4.8	7.4	13.5	19.2	23	27	30	33	36	43	53	61	74	80	43°	50°	53°	54°
	5070	5.2	8.6	15.8	22	27	32	35	39	42	50	61	71	87	94	43°	50°	53°	54°
	50100	6.4	12.3	23	32	39	45	50	55	60	71	88	101	124	134	44°	50°	52°	54°
40°	4040	4.0	4.9	9.0	12.8	15.6	18.1	20	22	24	29	35	40	50	53	33°	40°	44°	47°
	4050	4.4	6.2	11.3	16.0	19.5	23	25	28	30	36	44	51	62	67	33°	40°	43°	46°
	4060	4.8	7.4	13.5	19.2	23	27	30	33	36	43	53	61	74	80	33°	40°	43°	45°
	4070	5.2	8.6	15.8	22	27	32	35	39	42	50	61	71	87	94	33°	40°	43°	46°
	40100	6.4	12.3	23	32	39	45	50	55	60	71	88	101	124	134	34°	40°	43°	46°
25°	2540	4.0	4.9	9.0	12.8	15.6	18.1	20	22	24	29	35	40	50	53	23°	25°	32°	36°
	2550	4.4	6.2	11.3	16.0	19.5	23	25	28	30	36	44	51	62	67	23°	25°	32°	36°
	2560	4.8	7.4	13.5	19.2	23	27	30	33	36	43	53	61	74	80	23°	25°	33°	34°
	2570	5.2	8.6	15.8	22	27	32	35	39	42	50	61	71	87	94	23°	25°	33°	34°
	25100	6.4	12.3	23	32	39	45	50	55	60	71	88	101	124	134	23°	25°	28°	32°

# AIR-ATOMIZING NOZZLE

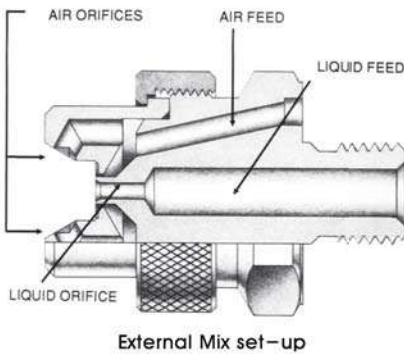
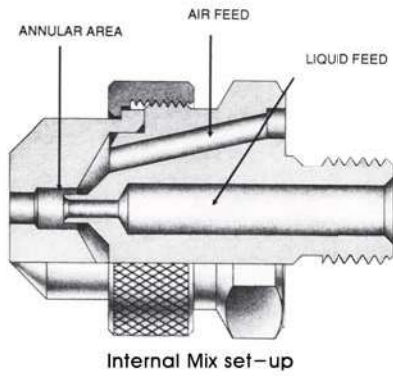
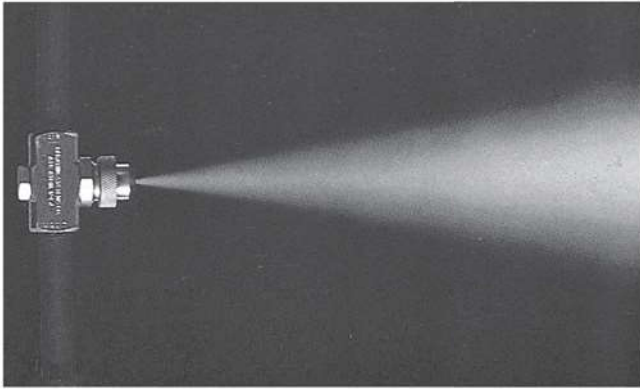

## Features

The AA nozzle uses the energy in compressed air to produce highly atomized sprays at low flow rates. There are many interchangeable components that can be assembled to achieve a variety of spraying objectives.

## Spray set-ups

AA nozzles produce three distinctly different types of sprays, depending on which interchangeable air and fluid caps are selected. The spray type and flow rate are determined by the "set up" — a specific combination of one air cap and one fluid cap.

## Materials

—Nickel-plated brass / Other materials and special materials

## Applications

—Humidification, spray adhesive, viscous material  
—spraying the coating of pharmaceutical and food processing

## Internal Mix set-up

### Features

The liquid and gas are mixed internally to produce a completely atomized spray. Available with Round, Wide-Angle Round, Flat Spray patterns.

## External mix set-up

### Features

The liquid atomization is controlled by varying the air pressure without changing flow rates. Effective for higher viscosity liquids and abrasive suspensions.

### Applications

- Humidity control: air humidifier, fermentation, culture, electrostatic painting
- Anti-Static: Plastic Injection Molding, Printing Plate
- Fine spray cooling: gas, waste gas, such as refractory cooling
- Combustion: waste incineration, two liquid mixture combustion
- Sterilization: sterilization unattended food factory, barn, piggery poultry humidification and disinfection
- Dust: cement, coke, glass raw materials, crushed stone other fine dust
- Odor Removal: Odor Remover Spray micro injection

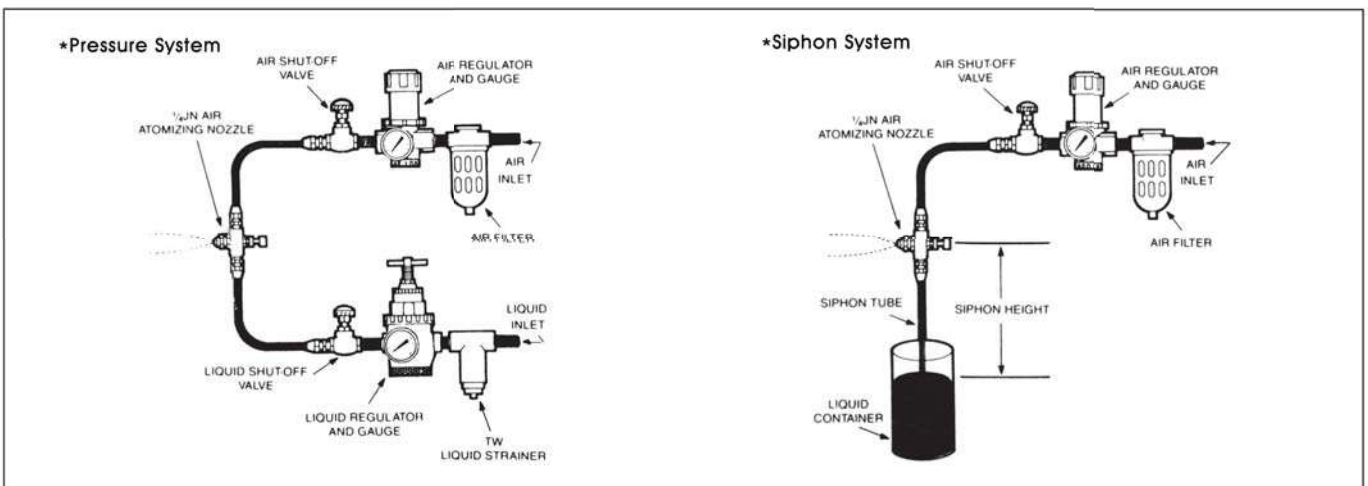

# AIR-ATOMIZING SET-UP



A. End Plug



B. Shut-Off



C. Clean-out



D. Clean-Out/Shut-Off



E. Air Operated Shut-Off(Square Body)



F. XA 01/02 Body with E or F Hardware (Round Body)

## Dimensions with Hardware Options for Square Body

Pipe Size	Hardware Option	W	X	Y	Max.Z
1/8 OR 1/4	A	20.6	42.9	49.2	14.3
	B				42.3
	C				63.5
	D				77.0
	E				103
	F				103
1/2	A	31.8	63.5	68.3	25.4

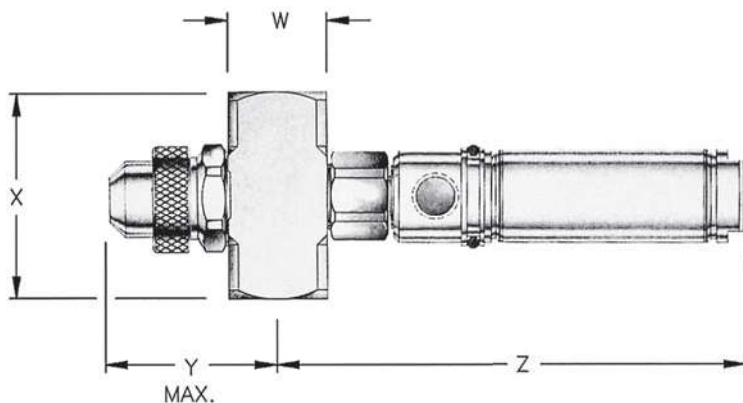

Overall Dimensions of AA Assemblies with Square (XA00) Body (Shown with E or F Hardware)

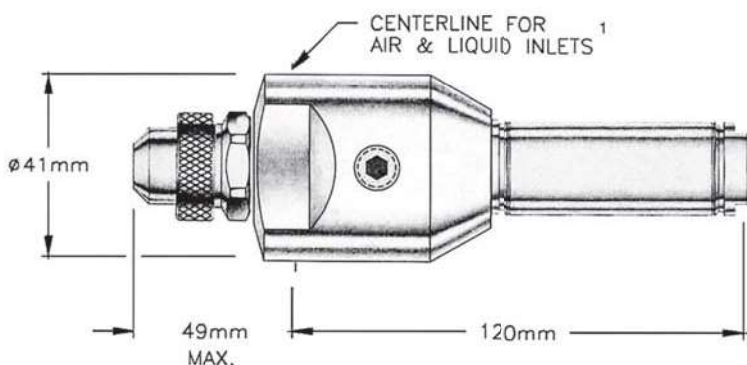

Overall Dimensions for Assemblies with Round (XA01, XA02) Bodies



1. Spray Extension

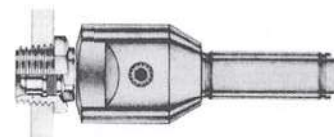

2. Mounting Bracket

# AIR-ATOMIZING NOZZLE

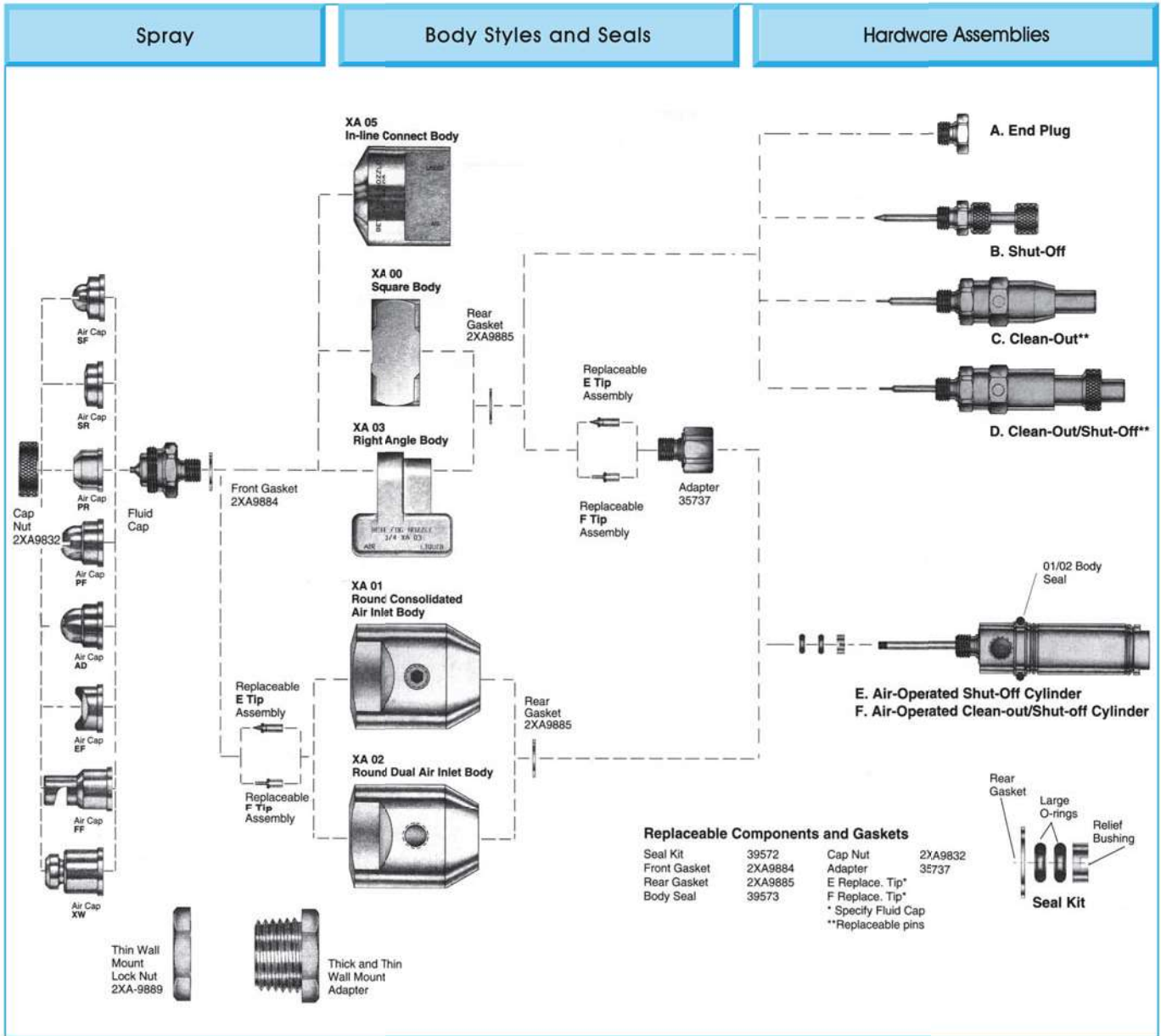

## TO ORDER

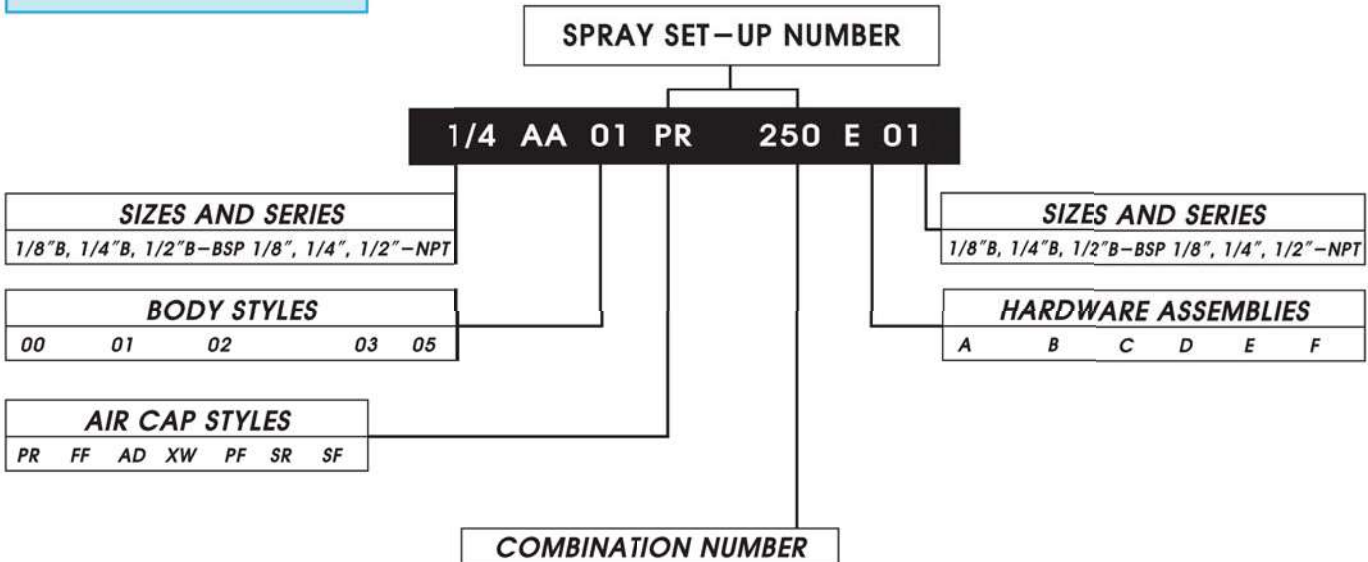

# AIR-ATOMIZING NOZZLE(1/4")

## AA-SR Series

Siphon Fed/ Round Spray Pattern

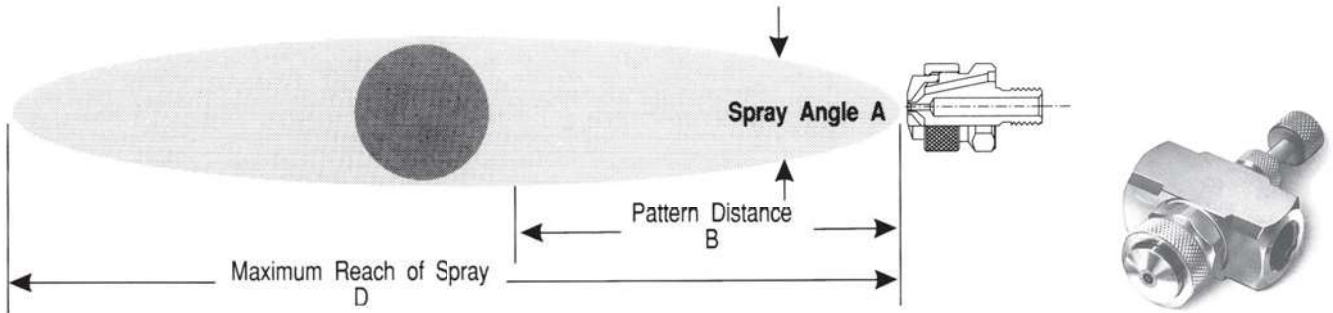

### Features

- lowest flow available
- Full cone pattern
- Very fine atomization
- Short to moderate forward spray projection
- Narrow spray angle(12° ~22° )

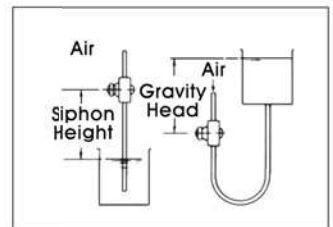

Set-up Number	Fluid and Air Cap Numbers	Atomizing Air		Liquid capacity in ℓ/h									Spray Dimensions at 200mm Siphon Height			
		Air Pressure kg/cm <sup>2</sup>	Air Capacity ℓ/min	Gravity Head			Siphon Height						Air kg/cm <sup>2</sup>	Spray Angle A°	B cm	D m
				45cm	30cm	15cm	10cm	20cm	30cm	60cm	90cm					
AA-SR050	Fluid Cap FC7 & Air Cap AC1201	0.7	11.3	1.5	1.3	1.1	0.87	0.68	0.53			0.7	18°	28	1.8	
		1.5	17.0	1.8	1.7	1.5	1.3	1.2	1.1	0.62		1.5	18°	28	1.9	
		3.0	28	2.1	1.9	1.7	1.5	1.4	1.3	1.1	0.76	3.0	18°	30	2.3	
		4.0	36	2.2	2.0	1.8	1.6	1.5	1.4	1.2	0.87	4.0	18°	36	2.6	
AA-SR150	Fluid Cap FC4 & Air Cap AC1201	0.7	13.3	2.4	2.1	1.7	1.5	1.2	0.79			0.7	18°	30	2.1	
		1.5	20	2.8	2.6	2.4	2.1	1.9	1.6	0.91		1.5	18°	33	2.3	
		3.0	32	3.4	3.1	2.9	2.8	2.6	2.4	1.7	1.1	3.0	18°	38	2.6	
		4.0	41	3.7	3.4	3.3	3.1	2.9	2.7	2.1	1.5	4.0	19°	43	3.0	
AA-SR200	Fluid Cap FC4 & Air Cap AC15202	0.7	23	2.5	2.3	2.0	1.6	1.4	1.1			0.7	18°	30	2.4	
		1.5	36	2.9	2.8	2.5	2.2	2.0	1.7	0.89		1.5	18°	33	2.7	
		3.0	58	3.4	3.3	3.2	2.9	2.8	2.5	1.9	1.2	3.0	19°	38	3.4	
		4.0	74	3.7	3.6	3.5	3.4	3.3	3.0	2.5	2.0	4.0	20°	43	4.0	
AA-SR250	Fluid Cap FC3 & Air Cap AC1202	0.7	19.3	4.5	4.0	3.4	2.1	1.8	1.4			0.7	21°	38	3.0	
		1.5	31	5.3	4.9	4.4	3.5	2.9	2.7	1.8		1.5	21°	41	3.4	
		3.0	50	6.0	5.6	5.0	4.4	4.0	3.4	2.4	1.2	3.0	21°	46	4.0	
		4.0	65	5.7	5.4	5.0	4.2	3.9	3.5	2.8	1.9	4.0	22°	51	4.6	
AA-SR400	Fluid Cap FC1 & Air Cap AC1204	1.5	58	22	19.9	16.3	12.3	10.5	8.3	2.8		1.5	17°	46	3.7	
		3.0	88	25	23	19.5	16.7	14.2	11.5	6.4	2.8	3.0	18°	51	4.3	
		4.0	111	26	24	21	18.4	15.7	12.9	7.9	4.5	4.0	18°	53	4.9	
		5.6	147	26	24	22	19.7	17.0	14.6	9.8	6.1	5.6	19°	58	5.5	
AA-SR450	Fluid Cap FC5 & Air Cap AC1205	2.0	144				27	22	16.8			2.0	20°	51	6.7	
		3.0	190				30	26	21			3.0	20°	53	7.0	
		4.0	240		43	40	31	28	23	11.0		4.0	21°	58	7.6	
		5.6	315	44	42	39	31	28	24	16.7	8.3	5.6	22°	63	8.2	

# AIR-ATOMIZING NOZZLE(1/4")

AIR-ATOMIZING NOZZLE(1/4")

## AA-PR Series

Pressure-fed / Internal Mix / Narrow Angle Round

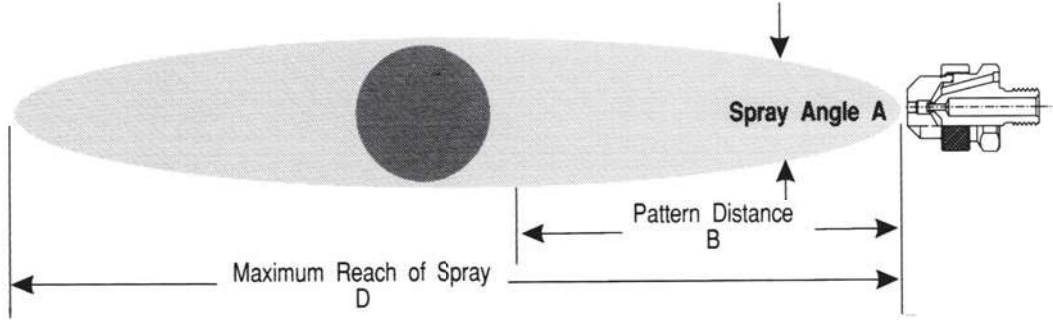

### Features

- Internal Mix
- Very fine atomization
- Narrow spray angle(12° ~22° )
- Full cone Pattern

Set-up Number	Fluid and Air Cap Numbers	Liquid Capacity ( ℓ /h) and Air capacity ( ℓ /m)															Spray Dimensions				
		Liquid Pressure																			
		0.7kg/cm <sup>2</sup>			1.5kg/cm <sup>2</sup>			2kg/cm <sup>2</sup>			3kg/cm <sup>2</sup>			4kg/cm <sup>2</sup>			Air Press kg/cm <sup>2</sup>	Liquid kg/cm <sup>2</sup>	A °	B cm	D m
AA-PR050	Fluid Cap FC4 & Air Cap AC1501	0.7	2.5	15.6	1.1	6.4	11.9	1.4	6.4	13.9	2.7	6.2	23	3.5	7.8	28	0.85	0.7	13°	30	2.7
		0.85	1.8	19.0	1.4	5.0	15.0	1.7	5.5	16.7	2.8	5.7	25	3.7	7.3	29					
		1.0	1.4	22	1.7	4.1	18.7	2.0	4.5	19.8	3.0	5.2	27	3.9	6.4	33					
					1.8	3.4	20	2.2	3.4	24	3.1	4.7	29	4.2	5.5	38					
					2.0	3.0	23	2.4	3.0	26	3.2	4.3	31	4.5	4.5	43					
					2.1	2.6	25	2.5	2.5	28	3.4	3.9	33	4.6	4.1	45					
AA-PR100	Fluid Cap FC4 & Air Cap AC1502	0.7	2.5	18.7	1.4	5.7	27	1.7	6.7	29	2.2	9.2	34	2.8	11.9	39	0.85	0.7	12°	43	3.7
		0.85	2.0	22	1.5	5.2	29	1.8	6.4	31	2.5	8.2	39	3.1	11.0	43					
		1.0	1.6	26	1.7	4.8	32	2.0	5.9	34	2.8	7.2	44	3.4	10.1	47					
					1.8	4.3	35	2.1	5.2	37	3.0	6.7	47	3.7	9.2	52					
					2.0	3.9	37	2.2	4.8	40	3.1	6.3	49	3.9	8.4	58					
					2.1	3.4	40	2.4	4.3	43	3.2	5.9	52	4.2	7.6	62					
AA-PR150	Fluid Cap FC3 & Air Cap AC1502	0.85	4.8	21	1.7	6.4	31	2.0	10.7	33	2.7	16.5	37	3.4	20	43	1.5	0.7	12°	48	4.0
		1.1	4.1	27	1.8	7.5	35	2.1	9.8	37	2.8	15.4	38	3.7	18.4	47					
		1.4	3.4	33	2.0	7.0	37	2.4	8.2	42	3.1	13.6	43	3.9	16.8	50					
		1.5	3.1	35	2.2	5.7	44	2.7	6.8	48	3.4	11.8	49	4.2	15.2	55					
		1.7	3.0	39	2.5	4.8	49	3.0	5.9	55	3.7	10.4	55	4.5	13.8	60					
		1.8	2.9	41	2.8	4.1	54	3.2	5.0	59	3.9	9.1	61	4.8	12.4	65					
AA-PR200	Fluid Cap FC2 & Air Cap AC1503	0.85	13.0	76	2.2	17.8	116	2.8	20	136	3.4	32	149	4.6	37	193	1.7	0.7	18°	66	4.9
		1.4	8.9	91	2.5	13.1	130	3.1	16.3	149	3.9	25	170	5.3	29	220					
		1.5	7.2	98	2.8	9.5	143	3.4	11.9	163	4.6	15.9	205	5.6	25	235					
		1.7	5.8	105	3.1	7.0	157	3.9	7.0	187	5.3	9.1	240	6.0	21	250					
		1.8	4.7	112	3.4	4.9	171	4.2	4.7	205	5.6	6.8	255	6.3	17.4	270					
		2.0	3.6	119	3.5	4.2	178	4.6	3.0	220	6.0	5.0	275	6.7	14.0	290					
AA-PR250	Fluid Cap FC1 & Air Cap AC1503	0.85	31	57	1.4	61	69	2.1	53	96	2.7	80	103	3.8	88	135	1.0	0.7	17°	81	4.9
		1.0	25	66	1.5	54	76	2.4	41	112	3.0	69	117	4.2	73	156					
		1.1	18.5	75	1.7	48	85	2.7	31	127	3.2	59	130	4.6	61	176					
		1.3	12.9	85	1.8	41	93	2.8	26	136	3.5	49	146	4.9	48	196					
					2.0	35	102	3.0	22	144	3.7	44	154	5.3	39	215					
					2.1	30	110				3.8	37	161	5.6	31	240					
AA-PR300	Fluid Cap FC5 & Air Cap AC1504	1.0	44	86	1.4	125	79	2.0	123	108	2.2	199	88	3.0	250	99	1.0	0.7	19°	89	6.1
		1.1	32	102	1.5	106	91	2.1	108	119	2.5	174	110	3.2	225	120					
					1.7	87	105	2.2	95	130	2.8	146	133	3.5	205	141					
					1.8	70	118	2.4	79	143	3.1	121	154	3.8	182	163					
					2.0	55	130	2.5	64	155	3.2	108	166	4.1	159	184					
								2.7	52	166	3.4	95	176	4.6	121	225					



# AIR-ATOMIZING NOZZLE(1/4")

## AA-EF Series

Pressure-fed / Internal Mix / Flat Fan

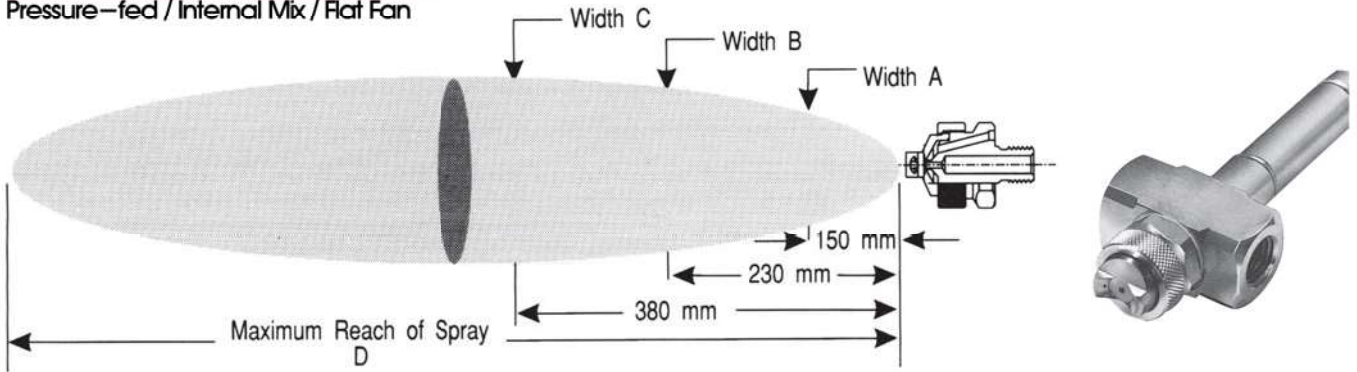

### Features

- External mix: allows spraying of viscous materials
- Variable atomization
- Moderate spray angle(60° ~90° )
- Precise metering of the liquid flow rate

Set-up Number	Fluid and Air Cap Numbers	Liquid Capacity ( ℓ /h) and Air capacity ( ℓ /m)															Spray Dimensions						
		Liquid Pressure																					
		0.2kg/cm <sup>2</sup>			0.3kg/cm <sup>2</sup>			0.7kg/cm <sup>2</sup>			1.5kg/cm <sup>2</sup>			3kg/cm <sup>2</sup>			Air	Liquid	A	B	C	D	
Air Press kg/cm <sup>2</sup>	Air ℓ/min	Liquid ℓ/h	Air Press kg/cm <sup>2</sup>	Air ℓ/min	Liquid ℓ/h	Air Press kg/cm <sup>2</sup>	Air ℓ/min	Liquid ℓ/h	Air Press kg/cm <sup>2</sup>	Air ℓ/min	Liquid ℓ/h	Air Press kg/cm <sup>2</sup>	Air ℓ/min	Liquid ℓ/h	Air Press kg/cm <sup>2</sup>	Air ℓ/min	Liquid ℓ/h	kg/cm <sup>2</sup>	kg/cm <sup>2</sup>	cm	cm	cm	m
AA-EF050	Fluid Cap FC7 & Air Cap AC1001	0.35	22		0.35	22		0.4	25		0.6	28		0.7	34		0.4	0.3	20	28	33	1.2	
		0.4	25		0.4	25		0.6	28		0.7	34		1.1	45		0.6	0.7	23	30	40	1.8	
				2.8			3.5				5.3			7.8			11.0	1.1	1.5	28	33	43	2.4
		0.5	27.5		0.6	28		0.7	34		1.1	45		1.8	62		1.4	1.5	25	30	41	2.7	
		0.6	28		0.7	34		0.85	40		1.4	54		2.5	79		1.1	2.0	28	35	48	2.6	
AA-EF100	Fluid Cap FC7 & Air Cap AC1003	0.21	25		0.35	26		0.7	31		1.4	45		2.8	74		0.21	0.21	9	15	23	0.9	
		0.35	26		0.7	31		1.1	40		1.75	54		3.5	85		1.1	0.21	9	15	23	1.2	
		0.7	31		1.1	40		1.4	45		2.1	59		4.2	102		1.4	0.35	10	15	23	1.2	
		1.1	40	2.8	1.4	45	3.5	1.75	54	5.3	2.8	74	7.8	4.9	119	11.0	1.4	1.4	11	18	25	1.5	
		1.4	45		1.75	54		2.1	59		3.5	85		5.25	127		1.75	0.7	11	15	24	1.5	
		1.75	54		2.1	59		2.8	74		4.2	102		5.6	139		2.8	1.4	13	18	28	1.8	
2.1	59		2.8	74		3.5	85		5.6	139		7.2	158		4.9	2.8	15	18	24	2.4			
AA-EF150	Fluid Cap FC4 & Air Cap AC1001	0.35	22		0.35	22		0.6	28		0.7	34		1.1	45		0.7	0.3	28	33	40	1.5	
		0.6	28		0.7	34		0.7	34		1.4	54		1.4	54		0.7	1.5	38	46	58	1.8	
				4.5			5.5				8.3			12.2			17.2	1.4	1.5	35	43	56	2.4
		0.7	34		1.1	45		1.4	54		2.1	71		2.1	71		2.5	1.0	33	40	51	3.0	
1.1	45		1.4	54		2.1	71		2.5	79		2.5	79		1.8	2.0	38	46	58	2.7			
AA-EF200	Fluid Cap FC4 & Air Cap AC1003	0.35	26		0.7	31		1.1	40		1.75	54		3.15	82		1.8	3.0	41	48	66	2.9	
		0.7	31		1.1	40		1.4	45		2.1	59		3.5	85		1.4	0.21	9	15	22	1.1	
		1.1	40		1.4	45		1.75	54		2.8	74		4.2	102		1.75	0.35	10	17	23	1.8	
		1.4	45	4.5	1.75	54	5.5	2.1	59	8.3	3.5	85	12.2	4.9	119	17.2	1.75	1.4	13	19	29	2.1	
		1.75	54		2.1	59		2.8	74		4.2	102		5.25	127		2.1	0.7	13	18	25	1.8	
		2.1	59		2.8	74		3.5	85		4.9	119		6.3	158		3.5	1.4	13	22	30	2.4	
		2.8	74		3.5	85		4.2	102		6.3	158		6.65	164		5.25	2.8	15	19	25	3.0	
AA-EF250	Fluid Cap FC3 & Air Cap AC1001	0.4	25		0.4	25		0.4	25		0.7	34		1.4	54		0.6	0.3	35	48	61	1.8	
		0.5	27.5		0.6	28		0.6	28		0.85	40		1.8	62		0.6	0.7	35	48	63	1.5	
				8.5			10.4				15.9			23			33	1.1	1.5	41	51	66	2.1
		0.6	28		0.65	31		0.7	34		1.1	45		2.1	71		1.4	1.5	43	53	66	2.4	
		0.7	34		0.7	34		0.85	40		1.4	54		2.5	79		1.8	2.0	41	51	69	2.7	
2.1	59		3.0	41		5.1	69		6.9	99		9.1	130		6.9	3.0	41	51	69	2.9			



# AIR-ATOMIZING NOZZLE(1/4")

## Spray Set Up 1/2 Series

Pressure-fed / External Mix / Flat Fan

Set-up Number	Fluid and Air Cap Numbers	Liquid Capacity (ℓ/h) and Air capacity (ℓ/m)															Spray Dimensions					
		Liquid Pressure																				
		0.2kg/cm <sup>2</sup>			0.3kg/cm <sup>2</sup>			0.7kg/cm <sup>2</sup>			1.5kg/cm <sup>2</sup>			3kg/cm <sup>2</sup>								
		Air Press kg/cm <sup>2</sup>	Air ℓ/min	Liquid ℓ/h	Air Press kg/cm <sup>2</sup>	Air ℓ/min	Liquid ℓ/h	Air Press kg/cm <sup>2</sup>	Air ℓ/min	Liquid ℓ/h	Air Press kg/cm <sup>2</sup>	Air ℓ/min	Liquid ℓ/h	Air Press kg/cm <sup>2</sup>	Air ℓ/min	Liquid ℓ/h	Air kg/cm <sup>2</sup>	Liquid kg/cm <sup>2</sup>	A cm	B cm	C cm	D m
AA-EF300	Fluid Cap FC3 & Air Cap AC1003	0.7	31		1.1	40		1.4	45		2.45	68		3.5	85		0.7	0.21	13	17	25	1.2
		1.1	40		1.4	45		1.75	54		2.8	74		4.2	102		1.75	0.21	13	17	25	1.8
		1.4	45	8.5	1.75	54	10.4	2.1	59		3.5	85	15.9	4.9	119		2.1	0.35	13	18	24	1.8
		1.75	54		2.1	59		2.8	74		4.2	102		5.25	127		2.45	1.4	14	20	32	1.8
		2.1	59		2.8	74		3.5	85		4.9	119		5.9	139		2.8	0.7	14	19	30	2.3
		2.8	74		3.5	85		4.2	102		5.6	139		6.3	158		4.2	1.4	14	20	36	3.0
3.5	85		4.2	102		4.9	119		6.3	158		7.0	175		5.25	2.8	17	20	30	4.0		
AA-EF350	Fluid Cap FC6 & Air Cap AC1002	0.6	91		0.7	102		1.4	156		2.1	210		3.2	285		1.4	0.3	33	38	48	3.8
		0.7	102	13.4	1.1	130	16.4	2.1	210	25	2.8	260	37	4.2	360	52	2.1	0.7	33	40	56	4.3
		1.1	130		1.8	184		2.5	235		3.5	310		5.3	430		3.2	1.5	35	46	58	4.0
		1.4	156		2.1	210		2.8	260		4.2	360		5.6	455		4.2	1.5	38	48	66	4.6
AA-EF400	Fluid Cap FC6 & Air Cap AC1004	0.7	85		1.05	102		1.4	116		2.45	178		3.15	212		0.7	0.21	13	19	25	1.7
		1.05	102		1.4	116		1.75	139		2.8	195		3.5	226		1.75	0.21	13	19	25	2.7
		1.4	116	13.4	1.75	139	16.4	2.1	156	25	2.45	178	37	4.2	266	52	2.1	0.35	15	19	28	3.0
		1.45	139		2.1	156		2.45	178		4.2	266		4.9	311		2.45	0.7	15	22	28	3.5
		2.1	156		2.8	195		3.5	226		4.9	311		5.6	359		2.45	1.4	17	23	36	3.7
		2.8	195		3.5	226		4.2	266		5.6	359		6.3	410		4.2	1.4	17	23	37	4.3
3.5	226		4.2	266		4.2	266		6.3	410		6.3	410		4.9	2.8	17	22	32	4.9		
AA-EF450	Fluid Cap FC6 & Air Cap AC1002	0.6	91		0.7	102		1.1	130		2.5	235		3.5	310		1.1	0.2	33	38	51	3.5
		1.1	130	17.6	1.4	156	22	1.8	184	33	3.2	285	48	4.6	380	68	2.5	1.5	38	46	64	3.8
		1.4	156		1.8	184		2.5	235		3.9	330		6.0	475		3.2	1.5	33	43	61	4.3
		1.8	184		2.1	210		2.8	260		4.2	360		6.7	525		4.2	2.0	33	43	61	5.2
AA-EF500	Fluid Cap FC2 & Air Cap AC1004	0.7	85		1.4	116		1.75	139		2.8	195		3.5	226		0.7	0.21	15	19	27	2.1
		1.05	102		1.75	139		2.1	156		3.15	212		4.2	266		1.75	0.21	15	19	27	3.0
		1.4	116	17.6	2.1	156	22	2.45	178	33	3.5	226	48	4.9	311	68	2.45	0.35	15	22	33	3.4
		1.75	139		2.45	178		2.8	195		4.2	266		5.25	340		2.8	0.7	15	22	36	3.8
		2.1	156		2.8	195		3.5	226		4.9	311		5.6	359		2.8	1.4	17	25	37	4.0
		2.8	195		3.5	226		4.2	266		5.6	359		6.3	410		4.2	1.4	17	25	37	4.9
3.5	226		4.2	266		4.9	311		6.3	410		6.65	427		5.25	2.8	18	23	36	5.8		
AA-EF550	Fluid Cap FC1 & Air Cap AC1002	0.7	102		1.1	130		1.8	184		3.2	285		5.3	430		2.1	0.3	40	56	76	3.7
		1.1	130	36	1.4	156	45	2.1	210	68	3.5	310	100	6.0	475	141	2.8	0.7	46	58	81	4.0
		1.4	156		2.1	210		2.8	260		4.9	405		6.0	525		3.2	1.5	48	58	79	4.3
		1.8	184		2.5	235		3.2	285		5.6	455		7.7	550		4.6	1.5	43	53	76	4.9
AA-EF600	Fluid Cap FC1 & Air Cap AC1004	1.05	102		1.75	139		2.45	178		3.15	212		3.85	255		1.05	0.21	15	20	25	2.7
		1.4	116		2.1	156		2.8	195		3.5	226		4.2	266		2.1	0.21	15	22	29	3.0
		1.75	139	36	2.45	178	45	3.15	212	68	3.85	255	100	4.55	297	141	2.8	0.35	18	24	36	3.5
		2.1	156		2.8	195		3.5	226		4.2	266		4.9	311		3.15	1.4	20	28	39	3.7
		2.45	178		3.15	212		4.2	266		4.9	311		5.6	359		3.5	0.7	19	27	38	4.0
		2.8	195		3.5	226		4.9	311		5.6	359		6.3	410		4.2	1.4	20	28	39	4.3
3.5	226		4.2	266		5.8	359		6.3	410		7.0	453		5.6	2.8	18	24	38	5.9		
AA-EF650	Fluid Cap FC8 & Air Cap AC1005	1.8	235		1.8	235		2.5	300		3.9	410					1.8	0.2	15	20	29	3.0
		2.1	260		2.1	260		2.8	330		4.2	445					2.8	0.2	15	20	30	3.4
		2.5	300	36	2.5	300	45	3.2	355	68	4.6	480	100	4.6	480		2.8	0.3	15	20	30	4.0
		2.8	330		2.8	330		3.5	380		4.9	520		5.3	565		3.5	0.7	17	22	32	4.3
		3.2	355		3.2	355		3.9	410		5.3	565		5.3	565		3.9	1.5	17	22	34	4.6
		3.5	380		3.5	380		4.2	445		5.6	600		6.3	685		4.2	1.0	17	23	33	4.7
4.2	445		4.2	445		4.9	520		6.3	685					4.9	1.5	17	23	34	5.5		
AA-EF700	Fluid Cap FC9 & Air Cap AC1005	2.1	260		2.8	330		3.9	410		4.9	520					2.1	0.2	17	24	34	3.5
		2.5	300		3.2	355		4.2	445		5.3	565					3.2	0.2	18	24	36	4.3
		2.8	330	64	3.5	380	78	4.6	480	119	5.6	600	175	6.0	640		3.9	0.3	18	25	36	4.9
		3.2	355		3.9	410		4.9	520		6.0	640		6.3	685		4.9	0.7	18	25	36	5.5
		3.5	380		4.2	445		5.3	565		6.3	685					4.9	1.5	20	25	38	5.5
		4.2	445		4.9	520		5.6	600		6.3	685					5.3	1.0	18	25	38	5.8
4.9	520		5.6	600		6.3	685								5.6	1.5	20	25	38	6.1		
AA-EF750	Fluid Cap FC5 & Air Cap AC1005	2.8	330		3.5	380		4.6	480		5.6	600					2.8	0.2	19	25	36	4.6
		3.2	355		3.9	410		4.9	520		6.0	640					3.9	0.2	20	25	37	4.9
		3.5	380	102	.2	445	125	5.3	565	182	6.3	685	280				4.6	0.3	20	25	37	5.2
		3.9	410		4.6	480		5.6	600		6.0	640					5.3	0.7	22	27	38	5.5
		4.2	445		4.9	520		6.0	640		6.3	685					5.6	1.0	22	27	41	5.5
		4.6	480		5.3	565		6.3	685								5.6	1.5	22	27	41	5.8
4.9	520		5.6	600											6.0	1.5	22	27	41	6.1		





# AIR-ATOMIZING NOZZLE(1/2")

## Spray Set Up 1/2 Series

### Dimensions and Weights

Nozzle Assembly	Dimensions						Weight Max (kg)
	J mm			K mm	H mm	W mm	
	Wide Round Set Up	Round Set Up	Flat Fan Set Up				
77, 78, 79, 89	70, 72, 82	75, 85					
1/2-A			24			0.60	
1/2-B	58	60	64	73	64	32	0.68
1/2-C				127			0.85

## AA-2PR SERIES Internal Mix : Narrow Angle Round

Set-up Number	Fluid and Air Cap Numbers	Liquid Capacity (ℓ/h) and Air capacity (ℓ/m)															Spray Dimensions					
		Liquid Pressure (kg/cm <sup>2</sup> )																				
		0.7kg/cm <sup>2</sup>			1.5kg/cm <sup>2</sup>			2kg/cm <sup>2</sup>			3kg/cm <sup>2</sup>			4kg/cm <sup>2</sup>								
		Air Press kg/cm <sup>2</sup>	Liquid ℓ/h	Air ℓ/min	Air Press kg/cm <sup>2</sup>	Liquid ℓ/h	Air ℓ/min	Air Press kg/cm <sup>2</sup>	Liquid ℓ/h	Air ℓ/min	Air Press kg/cm <sup>2</sup>	Liquid ℓ/h	Air ℓ/min	Air Press kg/cm <sup>2</sup>	Liquid ℓ/h	Air ℓ/min	Air Press kg/cm <sup>2</sup>	Liquid kg/cm <sup>2</sup>	A cm	B cm	C cm	D m
AA-2PR 72	Fluid Cap	1.3	34	350	1.7	146	365	3.0	230	510							1.4	0.35	9	16	25	6.7
		1.4	25	390	1.8	121	395	3.1	200	550							2.0	1.0				
	1.5	20	415	2.0	102	430	3.2	176	590							3.2	2.0					
	1.7	15.5	445	2.1	86	460	3.4	154	620													
Air Cap	2.3	72	490	3.5	135	660																
	2.4	60	520	3.6	118	700																
AA-2PR 82	Fluid Cap	0.7	134	315	1.3	320	440	2.1	575	570	3.0	740	710	3.9	840	860	0.7	0.35	1640	18	23	7.0
		0.85	100	380	1.4	255	520	2.2	505	640	3.1	690	770	4.1	790	930	1.4	1.0				
					1.5	200	590	2.4	440	720	3.2	630	840	4.2	740	990	2.5	2.0				
					1.7	154	670	2.5	380	790	3.4	570	910	4.4	690	1070	3.4	3.0				
								2.7	330	860	3.5	520	980	4.5	650	1140	4.5	4.0				
	Air Cap							2.8	275	930	3.7	470	1050	4.6	600	1210						
								3.0	235	1010	3.8	420	1120	4.8	550	1280						
								3.1	195	1080	3.9	345	1190	4.9	510	1350						
											4.1	325	1260	5.1	465	1430						
														5.2	425	1490						

## AA-2AD SERIES Internal Mix : Wide Angle Round

Set-up Number	Fluid and Air Cap Numbers	Liquid Capacity (ℓ/h) and Air capacity (ℓ/m)															Spray Dimensions						
		Liquid Pressure (kg/cm <sup>2</sup> )																					
		0.7kg/cm <sup>2</sup>			1.5kg/cm <sup>2</sup>			2kg/cm <sup>2</sup>			3kg/cm <sup>2</sup>			4kg/cm <sup>2</sup>									
		Air Press kg/cm <sup>2</sup>	Liquid ℓ/h	Air ℓ/min	Air Press kg/cm <sup>2</sup>	Liquid ℓ/h	Air ℓ/min	Air Press kg/cm <sup>2</sup>	Liquid ℓ/h	Air ℓ/min	Air Press kg/cm <sup>2</sup>	Liquid ℓ/h	Air ℓ/min	Air Press kg/cm <sup>2</sup>	Liquid ℓ/h	Air ℓ/min	Air Press kg/cm <sup>2</sup>	Liquid kg/cm <sup>2</sup>	A cm	B cm	C cm	D m	
AA-2AD 77	Fluid Cap								2.1	213	176	3.1	316	214	4.2	238	351	2.1	2.0	36	48	69	6.7
	Air Cap								2.3	127	249	3.2	195	292	4.3	154	439	3.2	3.0	36	48	69	7.3
AA-2AD 78	Fluid Cap	0.6	102	184	1.1	215	153	2.5	185	355	3.7	192	560	5.0	230	830	0.7	0.35	33	47	65	6.1	
		0.7	57	230	1.3	124	230	2.7	146	410	3.9	150	620	5.3	158	940	1.3	1.0					
	Air Cap	0.85	32	280	1.4	84	280	2.8	112	465	4.0	119	680	5.6	108	1080	2.8	2.0					
								3.0	86	520	4.2	86	770				4.0	3.0					
AA-2AD 79	Fluid Cap	0.7	129	325	1.7	182	540	3.1	265	810	4.3	350	1000				0.85	0.35	36	50	69	7.9	
		0.85	82	370	1.8	143	590	3.2	215	860	4.6	260	1080				1.7	1.0					
	Air Cap	1.0	45	415				3.4	173	910	5.0	186	1200				3.4	2.0					
								3.5	136	950							4.6	3.0					
AA-2AD 89	Fluid Cap	0.7	134	315	1.3	320	440	2.1	575	570	3.0	740	710	3.9	840	860	0.7	0.35	28	56	81	6.1	
		0.85	100	380	1.4	255	520	2.2	505	640	3.1	690	770	4.1	790	930	1.4	1.0					
					1.5	200	590	2.4	440	720	3.2	630	840	4.2	740	990	2.5	2.0					
					1.7	154	670	2.5	380	790	3.4	570	910	4.4	690	1070	3.4	3.0					
								2.7	330	860	3.5	520	980	4.5	650	1140	4.5	4.0					
	Air Cap							2.8	275	930	3.7	470	1050	4.6	600	1210							
								3.0	235	1010	3.8	420	1120	4.8	550	1280							
								3.1	195	1080	3.9	345	1190	4.9	510	1350							
											4.1	325	1260	5.1	465	1430							
														5.2	425	1490							



# AIR-ATOMIZING NOZZLE

**XAWM NOZZLE(1/4" )**

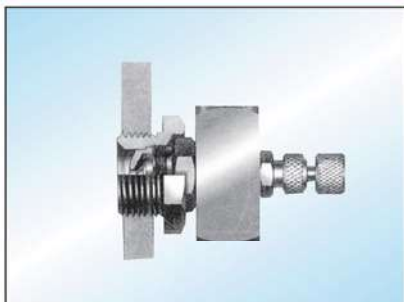

**Features**

- XAWM Nozzles replace Retainer Rings on nozzle assemblies and fit into threaded wall openings, holding the nozzle securely in place.
- Adapter is available in 3/4".

**XA05 NOZZLE(1/8" ,1/4" )**



**Features**

- The center lines of the air and liquid inlet entering in the back of the nozzle and parallel to the spray projection axis.

**XA06 NOZZLE(1/8" ,1/4" )**



**Features**

- Air and liquid inlet connections entering the nozzle at 90° to spray projection axis.

**XA MULTIPLE NOZZLE(1/4" )**



**Features**

- Five Spray Set-Ups located on the faces of the assembly or four set-ups located on the side faces.

**XADL NOZZLE(1/8" ,1/4" )**



**Features**

- Dual Spray assembly with opposing Spray Set-Ups perpendicular to opposing air and liquid inlets.

**XA DLH NOZZLE(1/8" ,1/4" )**



**Features**

- Two opposing Spray Set-Ups with the air and liquid inlet connections perpendicular to the spray axis.

**XA02 LM NOZZLE(1/4" )**



**Features**

- Provides accurate intermittent spray at speeds up to 180 cycles per minute.
- 6" or 12" (15 cm or 30 cm) lengths
- Suitable for spraying Slaked Lime



# AUTO SPRAY GUN



RA-100(Small Auto Spray Gun)



RA-200 (Large Auto Spray Gun)



RA-100L, 200L(Low Pressure Auto Spray Gun)

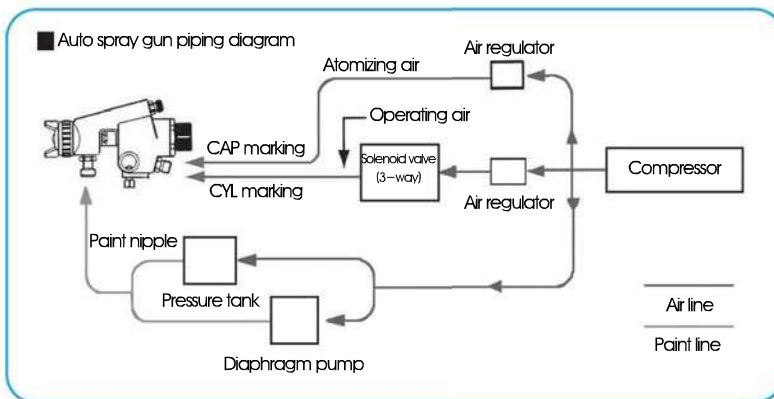

## PR-30

- Features**  
 - Flow rate, Spray angle is controllable  
 - Spray Type is controllable
- Applications**  
 - Paint, Release agent Spraying  
 - Glue, Syrup, Oil Spraying



Model	Type	Type of feed	Fluid nozzle orifice Ø mm	Spray distance mm	Atomizing air pressure MPa(kg/cm <sup>2</sup> )	Air consumption (l/min)	Fluid output (ml/min)	Pattern width (mm)	Approx. weight g	Applications		
wide use auto spray gun	Small	Pressure	RA100-P082	0.8	200	0.29(3.0)	270	150	190	460	Small products painting	
			RA100-P102	1.0			270	200	220		Small products painting	
			RA100-P132	1.3			260	250	230		Small products painting	
			RA100-P152	1.5			330	270	340		Large products painting	
			RA100-S182	1.8			330	290	340			
wide use auto spray gun	Large	Pressure	RA200-P202	2.0	250	0.29(3.0)	360	400	500	500	Large products painting	
			RA200-P251	2.5				550				330
			RA100R-P05	Round				Pressure				0.5
low pressure auto spray gun	Small	Pressure	RA100L-101	1.0	200	0.26(2.7)	430	150	460	460	Small products painting	
			RA200L-122	Large							1.2	0.20(2.0)



# AUTO SPRAY GUN

## Features

- Provides accurate intermittent spray at speeds up to 180 cycles per minute.
- Flow rate, Spray angle is controllable
- Spray Type is controllable

## Applications

- Paint, Release agent Spraying
- Glue, Syrup, Oil Spraying



## RA-60

Model	Type of feed	Fluid nozzle orifice	Applied air cap	Atomizing air pressure	Air consumption	Fluid output	Pattem width	Approx. weight
		mm		kg/cm <sup>2</sup>	l/min	ml/min	mm	g
RA-60-P082	Pressure	0.8	E2P	3.0	270	150	190	280
RA-60-P102		1.0	E2P		270	200	220	
RA-60-P102	Pressure (Gravity)	1.0	E2	2.5	145	180	200	
RA-60-P132		1.3	H2		260	250	230	
RA-60-P152		1.5	H2		260	270	245	
RA-60-P181		1.8	N1		190	310	240	
RA-60-P101		1.0	E1		2.7	430	150	200



## RA-80

Model	Type of feed	Fluid nozzle orifice	Applied air cap	Atomizing air pressure	Air consumption	Fluid output	Pattem width	Approx. weight
		mm		kg/cm <sup>2</sup>	l/min	ml/min	mm	g
RA-80-P122	Pressure	1.2	G2P	3.0	530	500	400	300
RA-80-P152		1.5	K2		330	270	340	
RA-80-P182	Pressure (Gravity)	1.8	R2	2.7	330	330	340	
RA-80-P202		2.0			360	400	320	
RA-80-P251		2.5			360	500	330	
RA-80-P122	Pressure	1.2	G2	2.7	500	500	300	

# AUTO GUN



## Features

- Provides accurate intermittent spray at speeds up to 180 cycles per minute.
- Produce distinctly different types of sprays patterns (flat, round, hollow cone) depending on which interchangeable nozzle tip selected.

## Applications

- Oil, Paint, Release agent auto spraying

## Materials

- 303,316 Stainless Steel
- other materials available upon request.

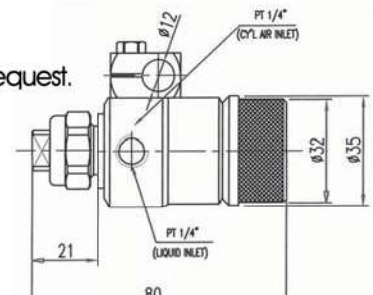

# AUTO SPRAY GUN

## AUTO SPRAY GUN SA-1, SA-2



	RA-C1	RA-C2	RA-CW
Features & Applications	<ul style="list-style-type: none"> <li>-Wide scope of purpose, and ideal for various industries.</li> <li>-Release agent, cooling, surface treatment</li> <li>-Press molding, odor removal</li> <li>-Plant humidification, and so on.</li> </ul>	<ul style="list-style-type: none"> <li>-Two separate air hoses (for piston operation &amp; atomization)</li> <li>-Superior atomization and uniform pattern</li> <li>-Available large capacity spray</li> </ul>	<ul style="list-style-type: none"> <li>-Wide angle round spray type</li> <li>-Provides accurate intermittent spray</li> </ul>

Disinfection		For release agent		Cooling		Adhesion	
Disinfection	Spraying disinfective liquids	Molding	Spraying mold release agents	Cooling	Spraying water to cool	Adhesion	Spraying bonding agents
Food processing		Marking		Surface treatment		Lubrication for products	
Food processing	Spraying cooking oils	Marking	Spray marking industrial components	Surface treatment	Spraying waterproof or antiseptic agents	Lubrication for products	Spraying mold release agents
Press molding		Oil supply		Rust prevention		Plant humidification	
Metal process work	Spraying lubricating oil	Oil supply	Spraying lubricants	Rust prevention	Spraying rust proof oils	Factory humidification	Spraying water
Humidifying for food		Mixing and coating		Odor removal		Powder/Dust humidification	
Food humidification	Spraying water	Mixing and coating	Spraying additives	Odor control	Spraying deodorizing agents	Powder/Dust humidification	Spraying water

# AUTO SPRAY GUN

## AUTO SPRAY GUN



Spray Type	Orifice Dia. mm	Capacity l /hour	Spray Pattern Size 300mm	Air Consumption (3kgf/cm <sup>2</sup> )
	0.5	0~3.6	200	60
	1.0	0~15	250	80
	1.3	0~21	350	100
	2.0	0~36	400	140

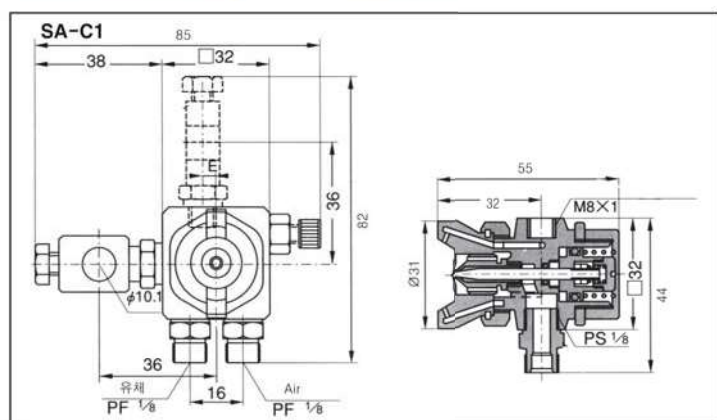

## HM Series

### Features

- Provides accurate intermittent spray
- Flow rate is controllable
- Siphon Fed / Compact Nozzle

### Applications

- Deodorization, mold release agent spraying, surface treatment



## Dimensions

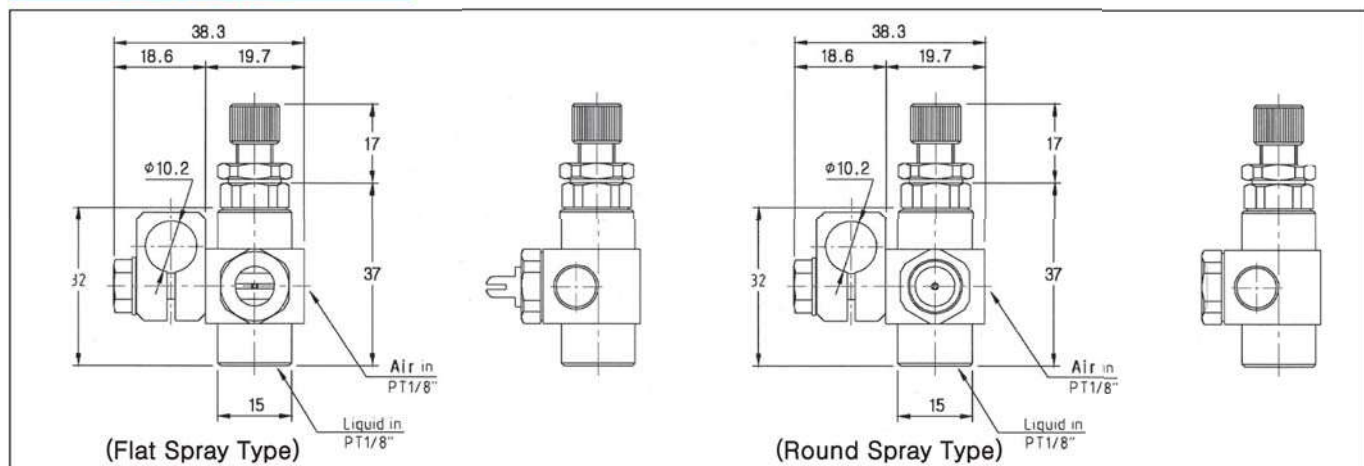

# PRESSURE TANK & DIAPHRAGM PUMP

## PRESSURE TANK

**Features** : Wheel type, easy to move, using air pressure only

**Capacity** : 10 l ~80 l

**Applications** : Paint, chemical solution, syrup, rust preventive oil



**AT-A** (Automatic)



**AT-M** (Manual)



**AT-2E** (2 l)

MODEL	CALACITY	WT.(KGS)	CUFT.(L/W/H)
AT-10	10 l	16.2	305 * 305 * 550
AT-20	20 l	26.1	415 * 360 * 695
AT-40	40 l	30.4	415 * 360 * 847
AT-60	60 l	35.6	500 * 500 * 880
AT-80	80 l	38.6	550 * 500 * 1000

## DIAPHRAGM PUMP



**Model: DPS-900**

Pressure ratio : 1:1  
 Maximum working pressure : 7kg/cm<sup>2</sup>  
 Maximum discharge : 20 l /min



**Model: PD-30**

Pressure ratio : 1:1  
 Maximum working pressure : 7kg/cm<sup>2</sup>  
 Maximum discharge : 20 l /min

# EDUCTOR NOZZLE



### Features

- Allows small pumps to circulate large volumes of liquid.
- Large flow opening minimizes plugging.
- The volume of discharge liquid will be 5 times greater than the motive liquid pumped.

### Materials

- Glass-filled polypropylene for excellent corrosion and chemical resistance.

### PRINCIPLE OF OPERATION

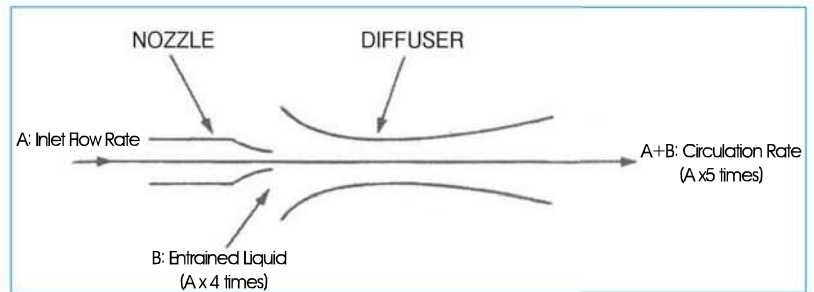

\* Pressurized liquid is pumped through the Eductor's nozzle and then diffuser. Between the nozzle and diffuser is a flow-through chamber that is open to the surrounding liquid. As liquid exits the diffuser at high velocity, surrounding solution is entrained into the flow-through chamber. This combination of pumped flow and pulled flow significantly increases circulation.

### Features

- Effective, economical way to circulate

### liquids in closed or open tanks

- No moving parts
- Inherently clog resistant
- Good in many applications up to 90° C
- Requires minimal maintenance
- Nozzle operation creates multiplying

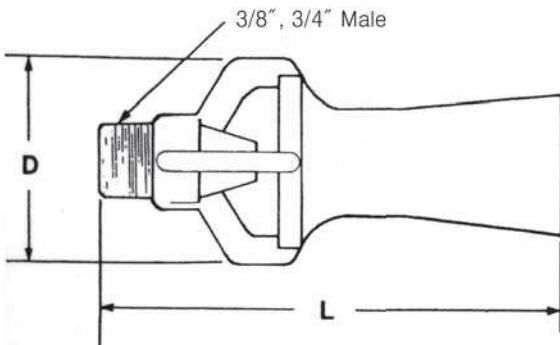

MODEL NO.	Flow Rate ( ℓ /min) at Liquid Pressure (kg/cm <sup>2</sup> )					
	1.0	1.5	2.0	2.5	3.0	3.5
9270-PP	60	73	85	95	104	112
33180-PP	40	50	57	63	70	75

MODEL NO.	PIPE CONNECTION	L	D
9270-PP	3/4BSPT (M)	162mm	74mm
33180-PP	3/8BSPT (M)	103mm	52mm

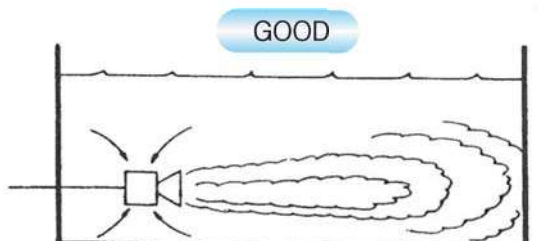
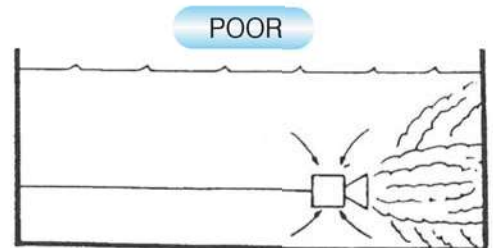

# MIST SPRAY NOZZLE

MIST SPRAY NOZZLE

## Hydraulic Mist Spray NOZZLE



### Features

- Finest fog of any direct pressure nozzle
- Uniform distribution, hollow cone spray pattern

### Materials

- Body - Stainless Steel, Brass
- Orifice, Core - Ceramic, Strainer - Stainless Steel

### Applications

Humidifying, cooling, disinfection, spraying rust proof oils, release agent

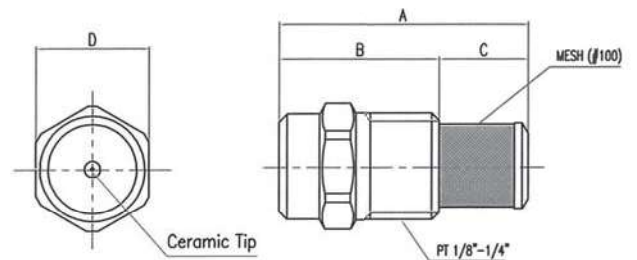

NOZZLE NO.	Flow Rate( ℓ /min)				Pressure(kg/cm <sup>2</sup> )					Spray Angle	Ofifice Dia ϕ	A (mm)	B (mm)	C (mm)	D (HEX)
	2	3	5	7	10	15	20	25	30						
	0.05	0.07	0.08	0.10	0.12	0.04	0.17	0.20	0.22	80°	0.4	1/8"	1/8"	1/8"	1/8"
SJ-FJ 4.8	0.07	0.08	0.10	0.13	0.15	0.18	0.22	0.25	0.27	80°	0.5	(24)	(18)	(6)	(11)
(1/8" - 1/4")	0.14	0.16	0.20	0.26	0.30	0.35	0.43	0.49	0.55	80°	0.7	1/4"	1/4"	1/4"	1/4"
	0.22	0.25	0.30	0.38	0.45	0.53	0.65	0.74	0.82	80°	0.8	(26)	(20)	(6)	(14)

## FOG NOZZLE

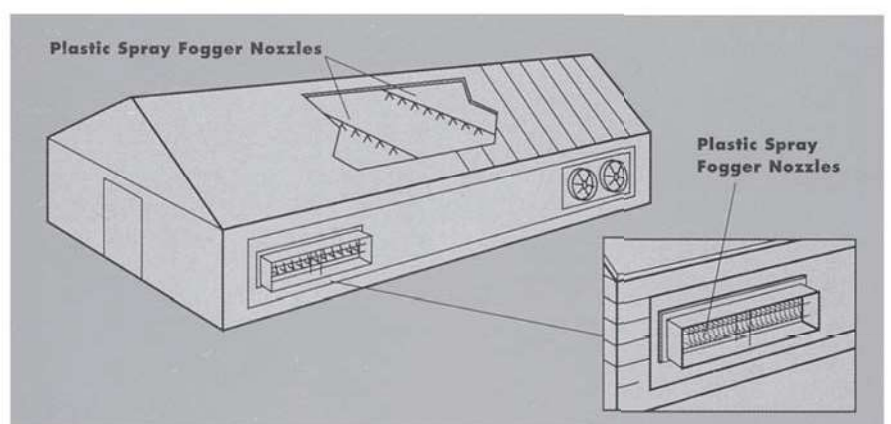

### Plastic Spray Fogger Nozzles Performance Data

NOZZLE NO.	Inlet Conn. NPT or BSPT (M)	Capacity · gph(l/hr)					Spray Angle			Vinyl cap color
		20 psi (1.5 bar)	40 psi (3 bar)	100 psi (7 bar)	150 psi (10 bar)	200 psi (14 bar)	40 psi (3 bar)	100 psi (7 bar)	200 psi (14 bar)	
1/8SF- CE1	1/8"	0.45(1.8)	0.63(2.5)	1.0(3.8)	1.2(4.5)	1.5(5.4)	110°	110°	100°	Blue
1/8SF- CE2	1/8"	0.90(3.5)	1.3(5.0)	2.0(7.6)	2.4(9.1)	2.8(10.8)	105°	105°	100°	Yellow
1/8SF- CE3	1/8"	1.3(5.3)	1.9(7.5)	3.0(11.4)	3.7(13.7)	4.2(16.2)	110°	110°	100°	Green
1/8SM - CE1	1/8"	0.71(2.8)	1.0(3.9)	1.6(6.0)	1.9(7.2)	2.2(8.5)	80°	75°	75°	White
1/8SM - CE2	1/8"	1.4(5.6)	2.0(7.9)	3.2(12.0)	3.9(14.4)	4.5(17.0)	80°	75°	75°	Black

# Air atomizing fine header

## Features

- Mist and uniform article size
- Suitable for products requiring uniform washing

## Features

- AIR ATOMIZING FINE HEDER

### Outside view

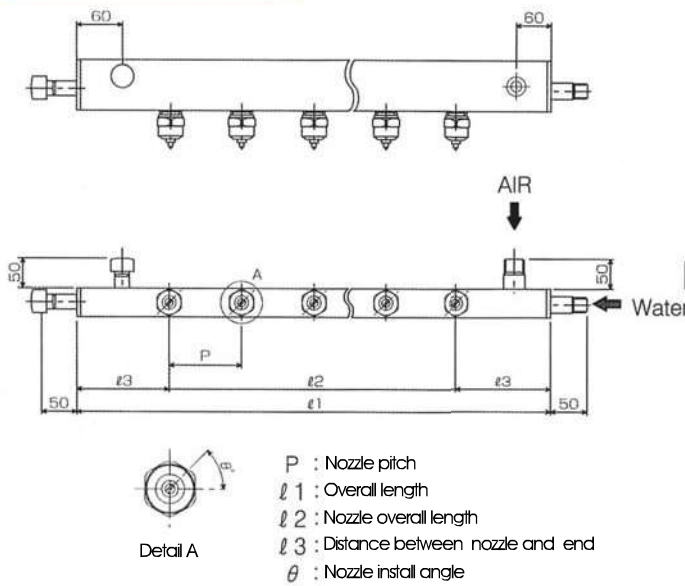

### Application exam

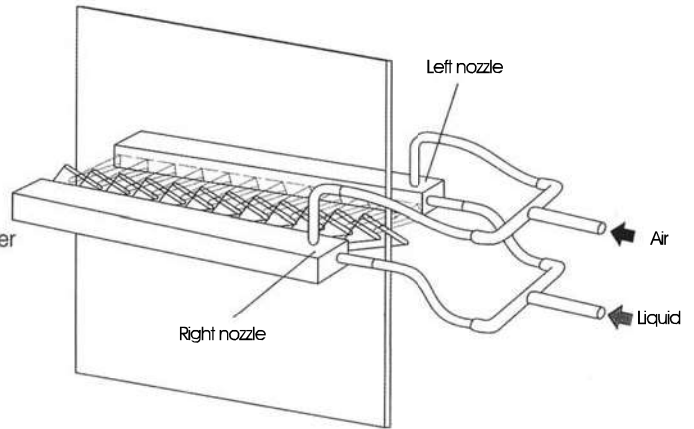

### Flow chart

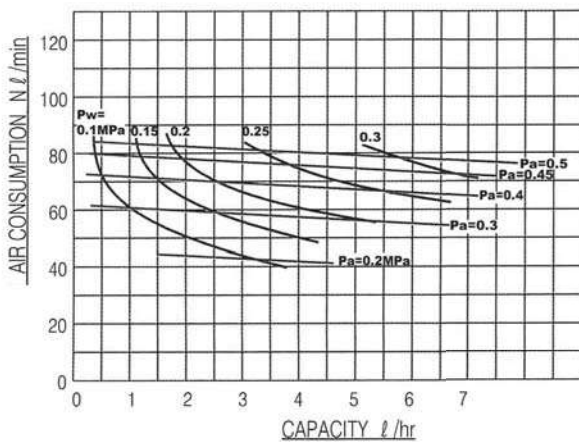

### Technical data

Measure condition: Air pressure (0.4MPa) Liquid pressure (0.2MPa), Spray distance

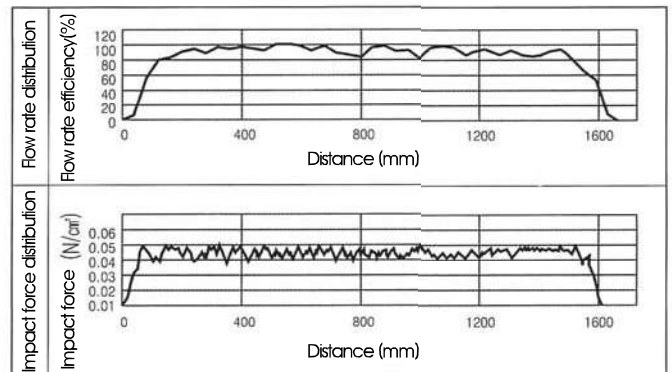

### Performance data

NOZZLE SET-UP	AIR PRESSURE (MPa)	WATER PRESSURE (MPa)	AIR CAPACITY (Nm <sup>3</sup> /Hr)	WATER CAPACITY (L/min)
AA-PF350	0.5	0.5	5.4	1.1

\*The dimensions can be changed according to design requirements.

## COMMON INFORMATION OF NOZZLE

### 1. Definition of nozzle

A nozzle is a device designed to control the direction or characteristics of a fluid flow (especially to increase velocity) as it exits (or enters) an enclosed chamber or pipe.

### 2. Spray performance considerations

#### 1) Specific Gravity

Specific gravity is the ratio of the mass of a given volume of liquid to the mass of the same volume of water. In spraying, the main effect of the specific gravity of a liquid (other than water) is on the capacity of the spray nozzle.

#### 2) Temperature

The values given in the catalog are based on spraying water at 70° F (21° C). Although liquid temperature changes do not affect the spray performance of a nozzle, they often affect viscosity, surface tension and specific gravity which do influence spray nozzle performance.

SUS 303 – SUS 304	: 430°C available from
SUS 316	: 430°C – (760)1000°C available from
SUS316L	: 1000°C – 1200°C available from
PP	: 71°C
VITON	: 204°C
PVC	: 60°C
STEEL	: 371°C
BRASS-COPPER	: 204°C
ALUMINA CERAMIC	: 1371°C
SILICON CARBIDE	: 1704°C

### 3) Viscosity

Liquid viscosity is a primary factor affecting spray pattern formation and, to a lesser degree, capacity. High viscosity liquids require a higher minimum pressure to begin formation of a spray pattern and provide narrower spray angles as compared to those of water.

### 4) Operating pressure

The values given in the tabulation sections of this catalog indicate the most commonly used pressure ranges for the associated spray nozzle or accessory. Some spray nozzles and accessories can perform below or above the pressures shown, while others can be modified at our factory or redesigned to accommodate the requirements of specific new applications.

a)Low pressure	: 5kg/cm <sup>2</sup> below (PVC,PP,SUS,BRASS)
b)Medium Pressure	: 5~21kg/cm <sup>2</sup> below (SUS,BRASS)
c)High pressure	: –Ceramics Tip : NEEDLEJET
	–TC TIP : paint,DESCALING NOZZLE
	–SUS6316L : FLOW BACK NOZZLE
	–HSS : MEG High pressure washing nozzle



### 3. Nozzle wear

Nozzle wear is typically characterized by an increase in nozzle capacity, followed by a general deterioration of the spray pattern. Flat fan spray nozzles with elliptical orifices experience a narrowing of the spray pattern. In other spray pattern types, the distribution within the spray pattern deteriorates without substantially changing the coverage area.

#### Approximate abrasion resistance ratios

- ①ALUMINUM : 1
- ②BRASS : 1
- ③STEEL : 1.5~2
- ④MONEL : 2~3
- ⑤SUS 303, 304 : 4~6
- ⑥HASTELLOY : 4~6
- ⑦HSS : 10~15
- ⑧STELLITE : 10~15
- ⑨CERAMICS : 90~200
- ⑩Nitride Bonded : 90~130
- ⑪Carbides(T.C초경) : 180~250

#### Important SI unit

NO	Name	Symbol	Previous unit→SI unit	SI unit→Previous unit
1	Pressure	Mpa	1kgf/cm <sup>2</sup> ≒0.098Mpa	1Mpa≒10.2kgf/cm <sup>2</sup>
2	Force	N	1kgf≒9.8N	1N≒0.102kgf
3	Moment of force	N·m	1kgf·m≒9.8m	1N·m≒0.102kgf·m
4	Vacuum pressure	-KPa	-1mmHg≒-0.133kPa	-1kPa≒-7.5mmHg
5	Moment of inertia	kg·m <sup>2</sup>	1kgf·cmS <sup>2</sup> ≒0.098kg·m <sup>2</sup>	1kgf·m <sup>2</sup> ≒10.2kgf·cm·S <sup>2</sup>
6	Kinetic energy	J	1kgf·cm≒0.098J	1J≒10.2kgf·cm

#### Conversion table Pressure Mpa→kgf/cm<sup>2</sup>

Mpa	0.001	0.002	0.003	0.004	0.005	0.006	0.007	0.008	0.009	0.01	0.011	0.012	0.013	0.014	0.015	0.016	0.017	0.018	0.019
kgf/cm <sup>2</sup>	0.01	0.02	0.03	0.04	0.05	0.06	0.07	0.08	0.09	0.1	0.11	0.12	0.13	0.14	0.15	0.16	0.17	0.18	0.19
Mpa	0.02	0.03	0.04	0.05	0.06	0.07	0.08	0.09	0.1	0.11	0.12	0.13	0.14	0.15	0.16	0.17	0.18	0.19	0.2
kgf/cm <sup>2</sup>	0.2	0.31	0.41	0.51	0.61	0.71	0.82	0.92	1.0	1.1	1.2	1.3	1.4	1.5	1.6	1.7	1.8	1.9	2.0
Mpa	0.3	0.4	0.5	0.6	0.7	0.8	0.9	1.0	1.1	1.2	1.3	1.4	1.5	1.6	1.7	1.8	1.9	2.0	2.5
kgf/cm <sup>2</sup>	3.1	4.1	5.1	6.1	7.1	8.2	9.2	10.2	11.2	12.2	13.3	14.3	15.3	16.3	17.3	18.4	19.4	20.4	25.5
Mpa	3.0	3.5	4.0	4.5	5.0	5.5	6.0	6.5	7.0	7.5	8.0	8.5	9.0	9.9	10	20	30	40	50
kgf/cm <sup>2</sup>	30.6	35.7	40.8	45.9	51.0	56.1	61.2	66.3	71.4	76.5	81.6	86.7	91.8	101.0	102	204	306	408	510

#### Understanding of particle size

Particle size MVD(μ)	Relevant particle	Time to need to fall 3m (Second)	Distance between a falling out 3m pushed wind of 2m/h	The number of particles per unit area falling if 10 liters of water sprayed on the area of 100 m <sup>2</sup>
5000~2000	Heavy rain	0.85~0.9	1.7~0.9	1.5~24(EA/m <sup>2</sup> )
2000~1000	Downpour	0.9~1.1	1.8~1.1	24~191(EA/m <sup>2</sup> )
1000~500	Moderate rain	1.1~1.6	2.2~1.6	191~1,528(EA/m <sup>2</sup> )
500~100	Light rain	1.6~11	3.2~11	1,528~190,000(EA/m <sup>2</sup> )
1000~50	Scotch mist	11~40	22~40	19~153(EA/m <sup>2</sup> )
50~10	Wet fog	40~1,020	80~1,020	153~19,100(EA/m <sup>2</sup> )
10~2.0	Dry fog	1,020~25,400	2,040~25,400	19,000~23,870,000(EA/m <sup>2</sup> )
1.0~0.01	Fog	Floating in the air*	-	-
0.01~0.001	Smoke	Floating in the air*	-	-
0.001 below	Molecule size	-	-	-

\*Particle size less than 1μm is suspended in the air by Brownian motion.